



CREATOR

5891



1

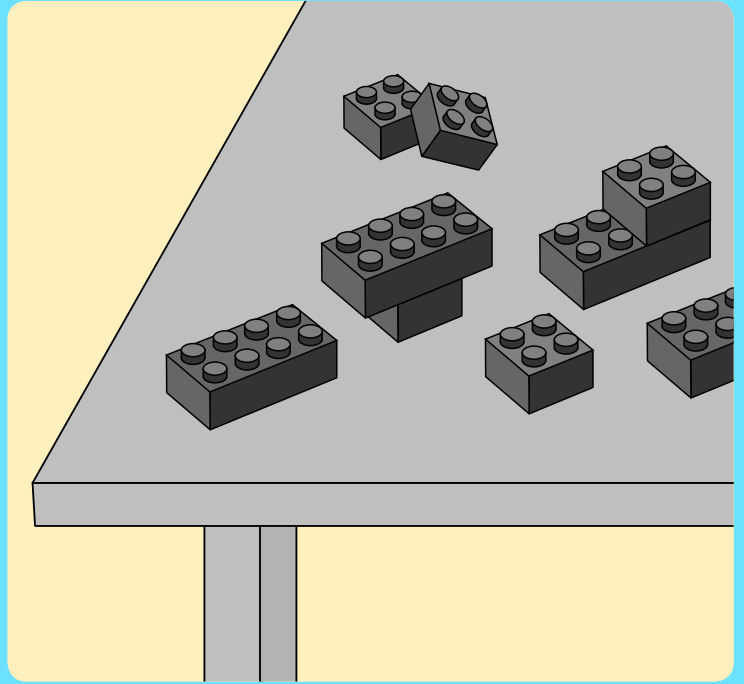
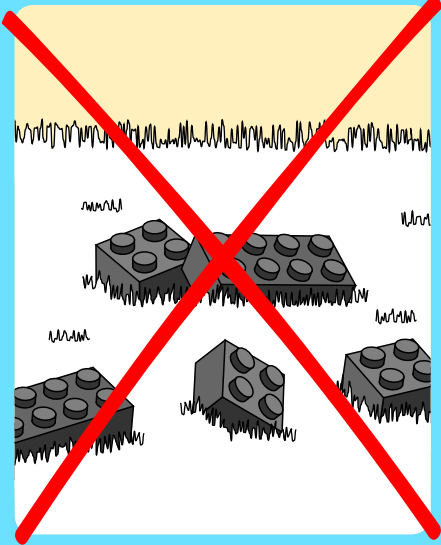

2

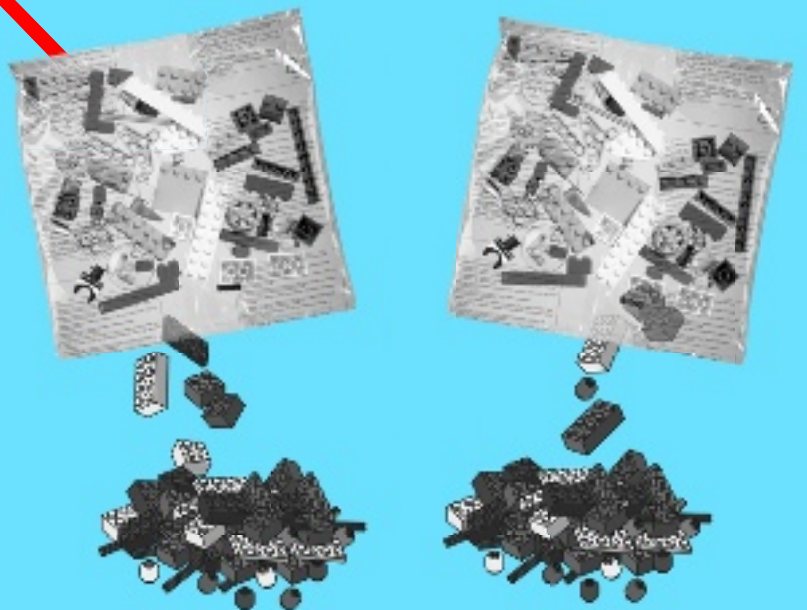



2x

1

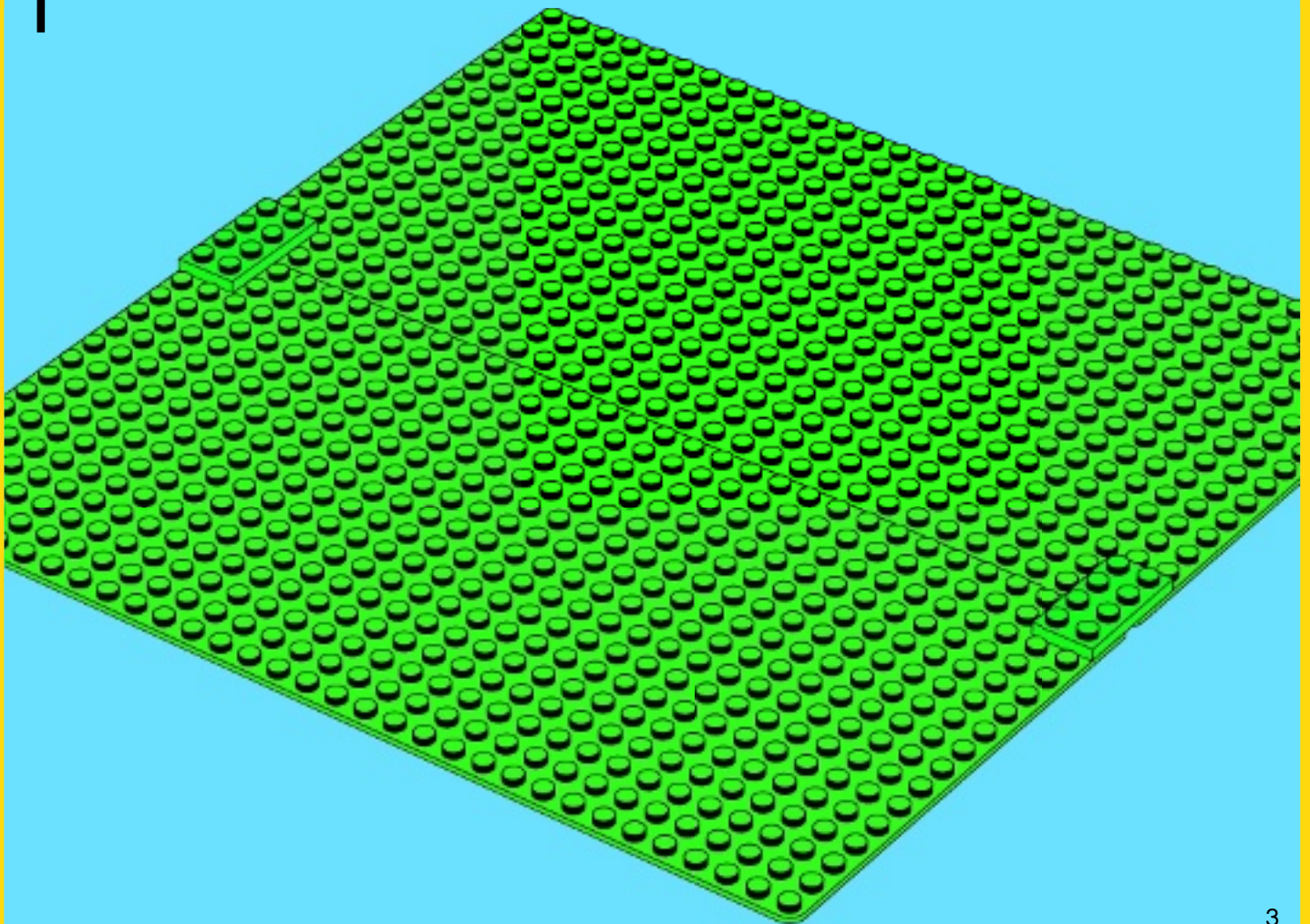



1x



1x



1x

2

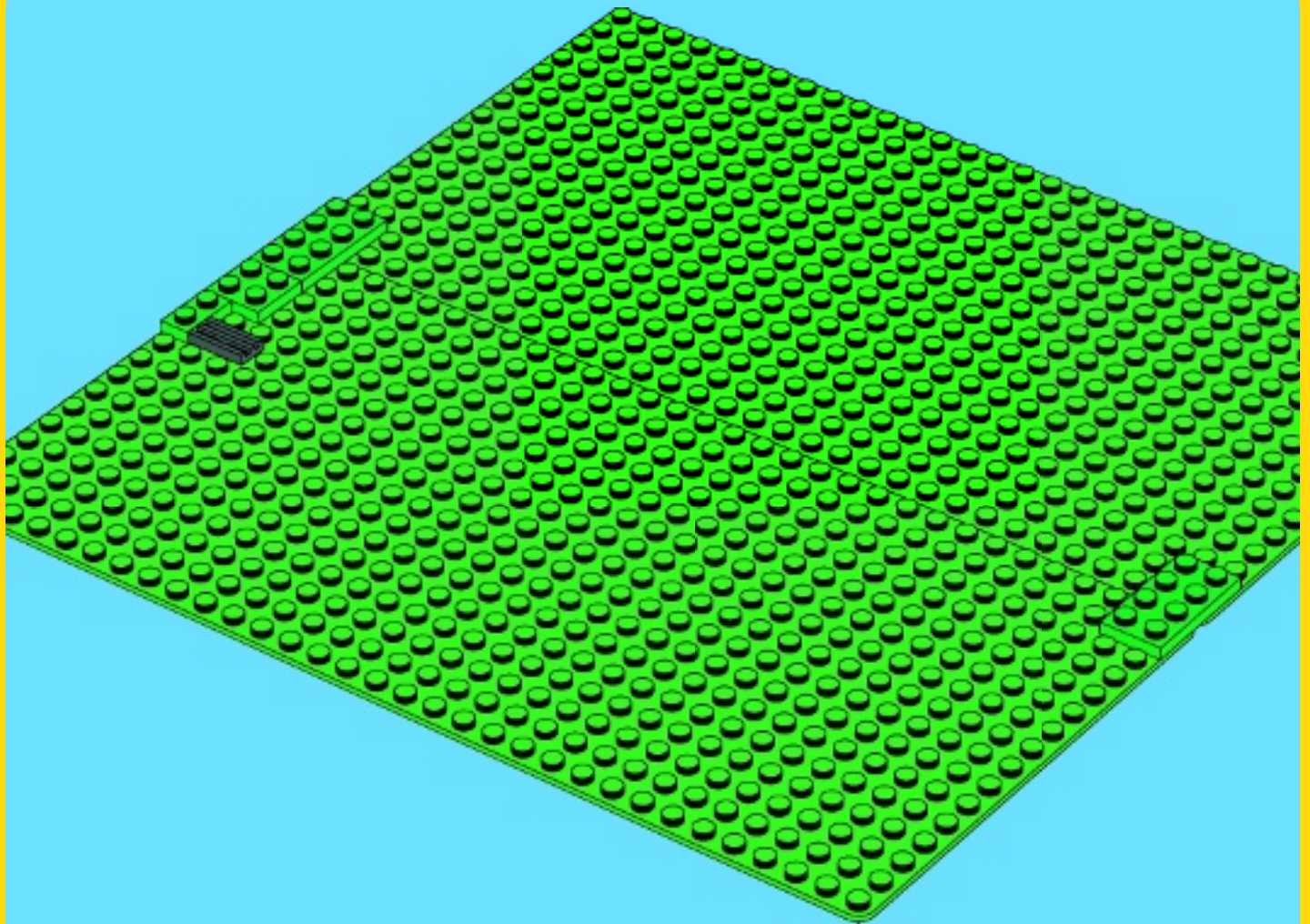

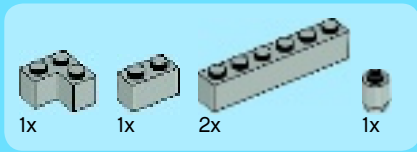

3

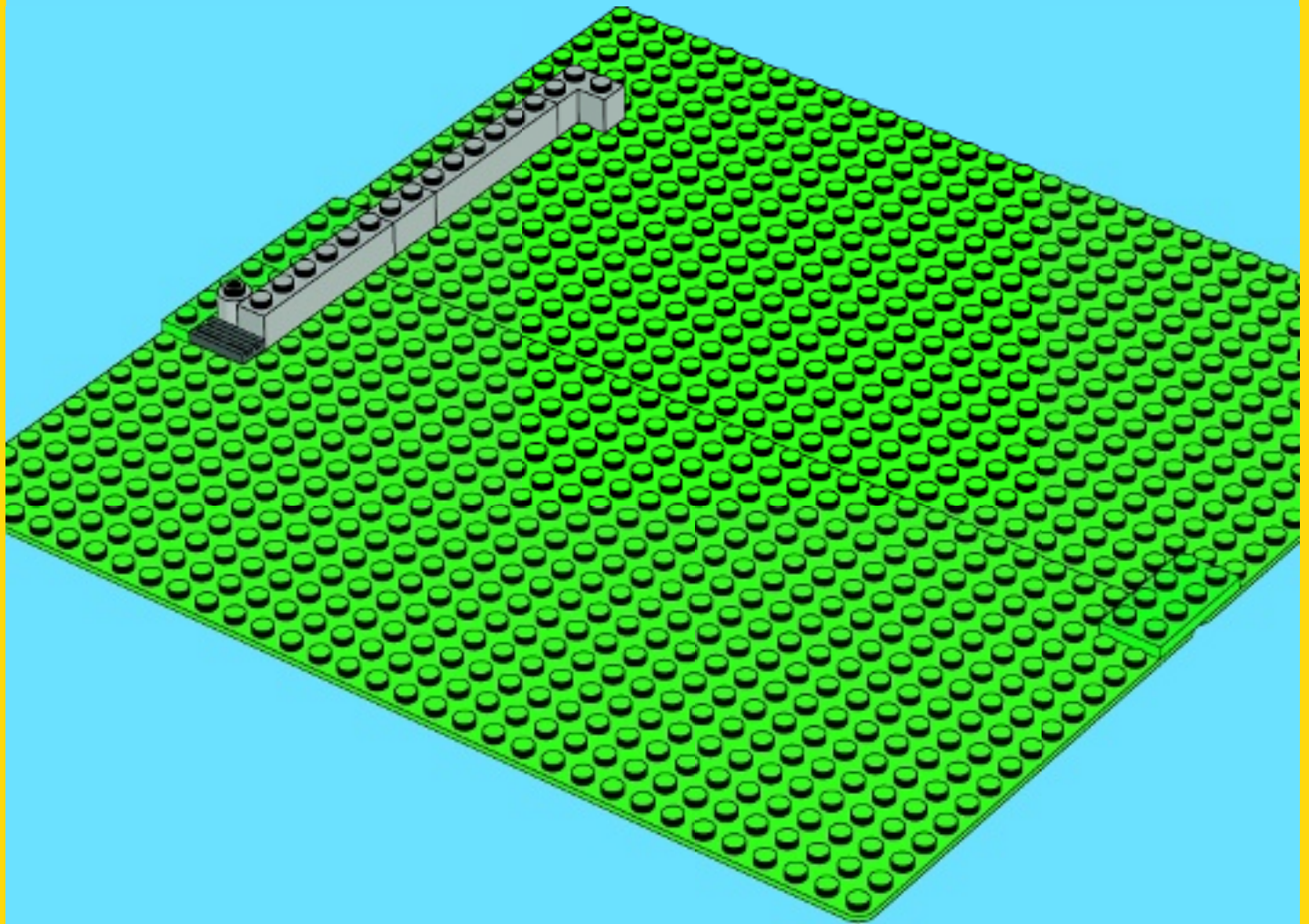

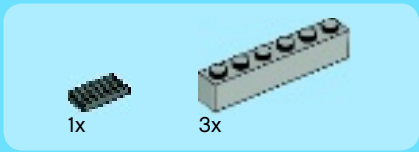

4

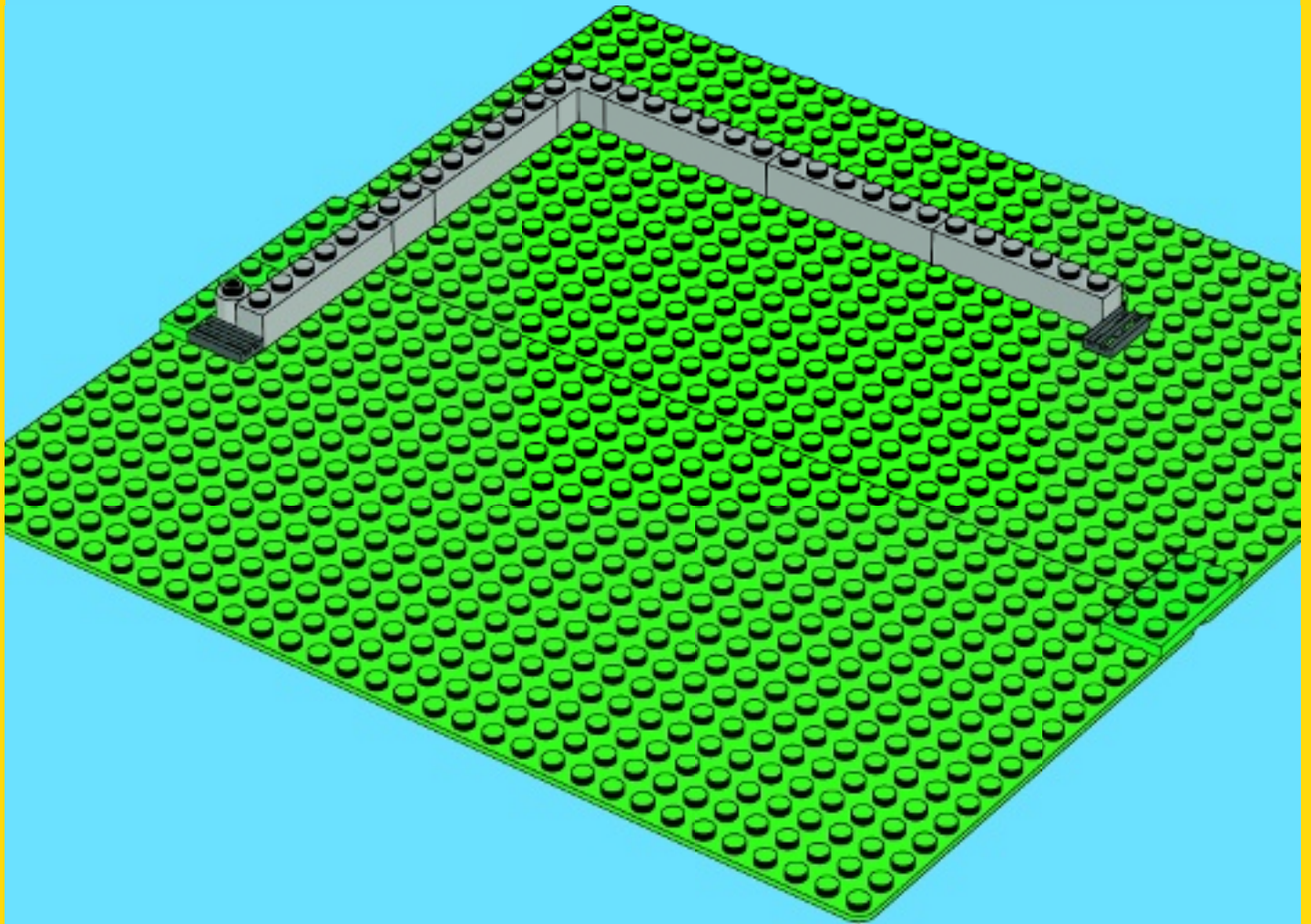



1x



1x



3x



2x

5

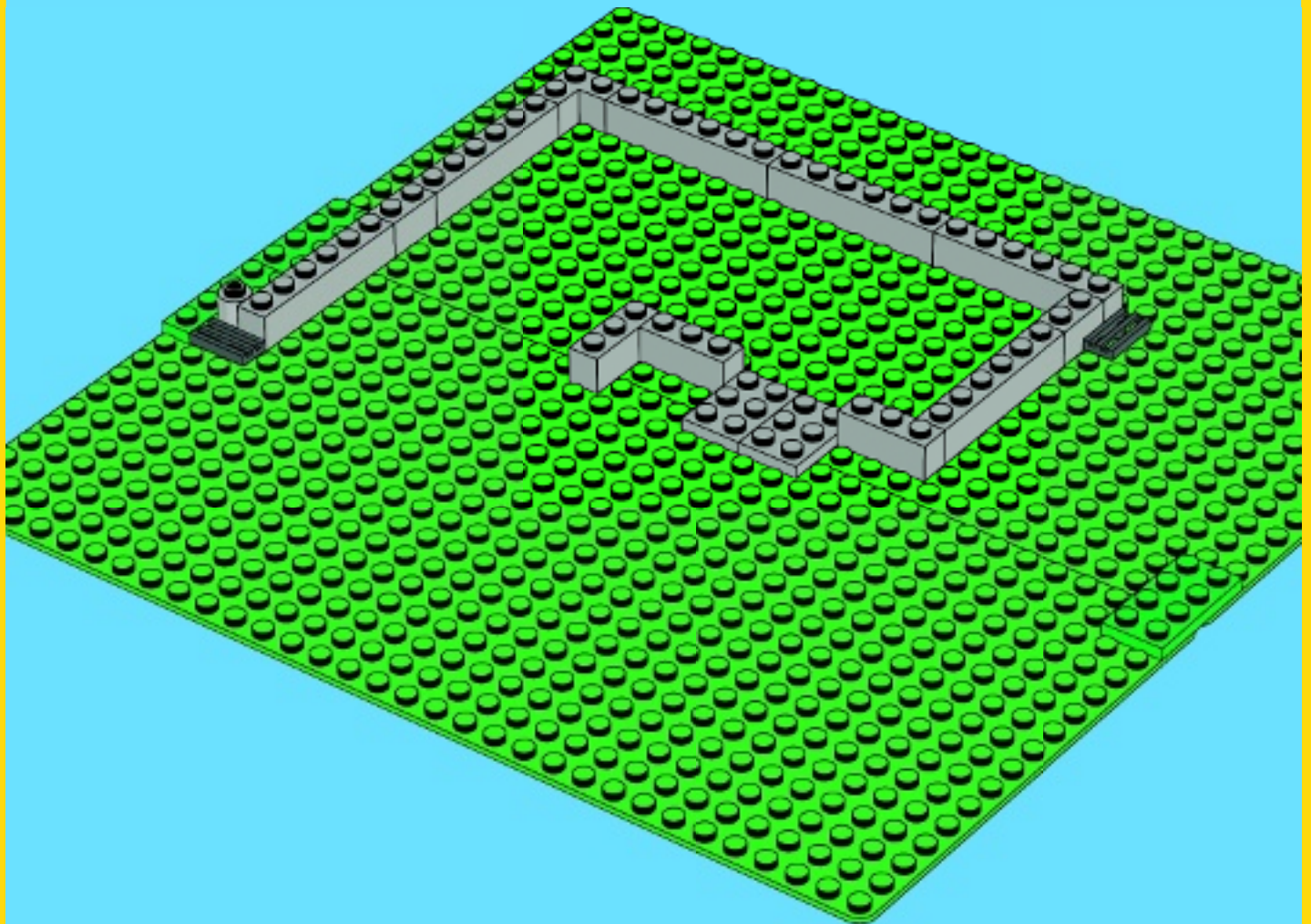



1x



2x



8x

6

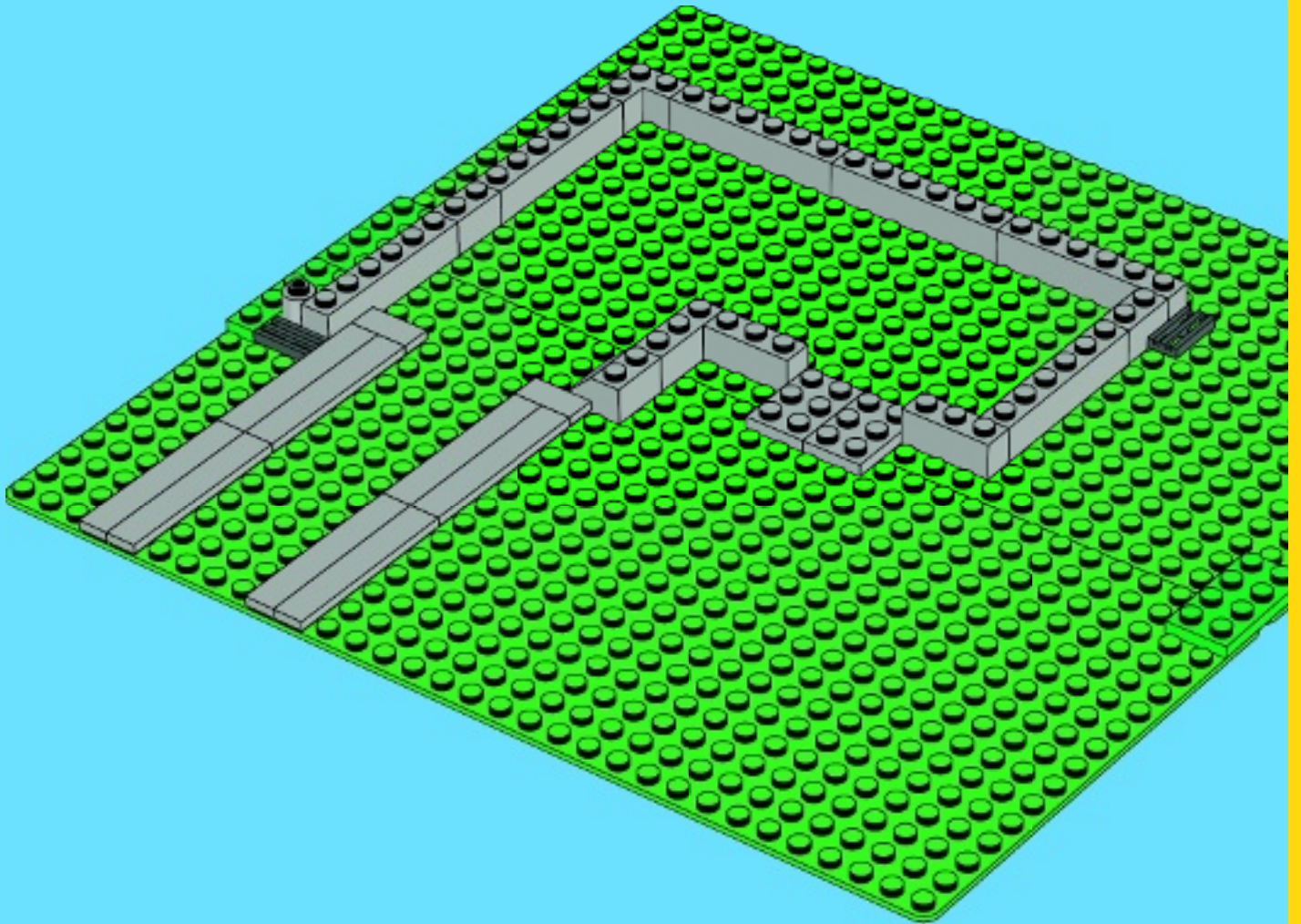

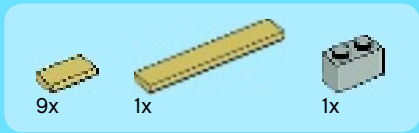

7

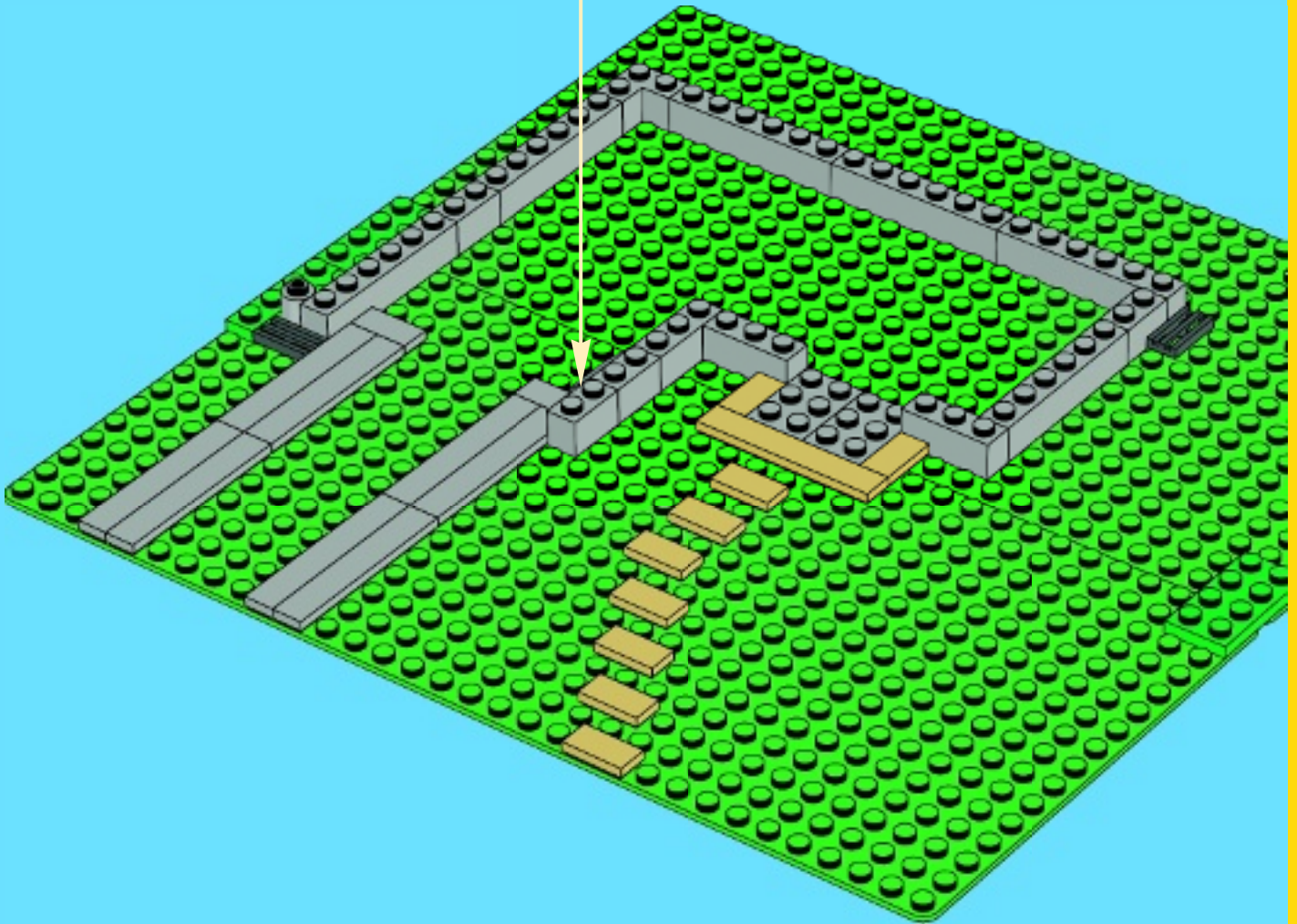
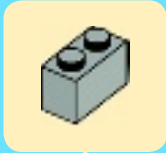



2x



4x



4x

8

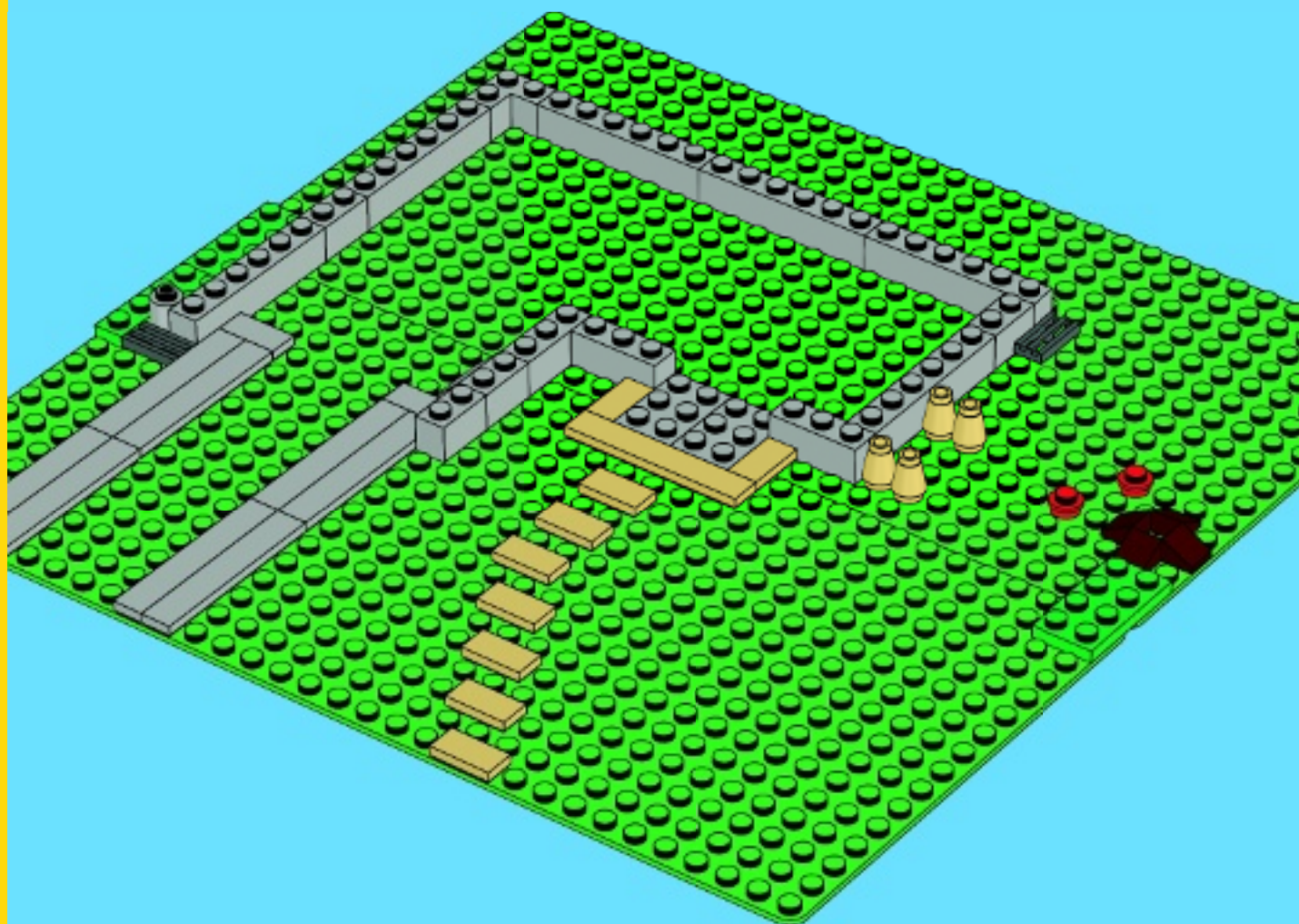



3x



1x



2x

9

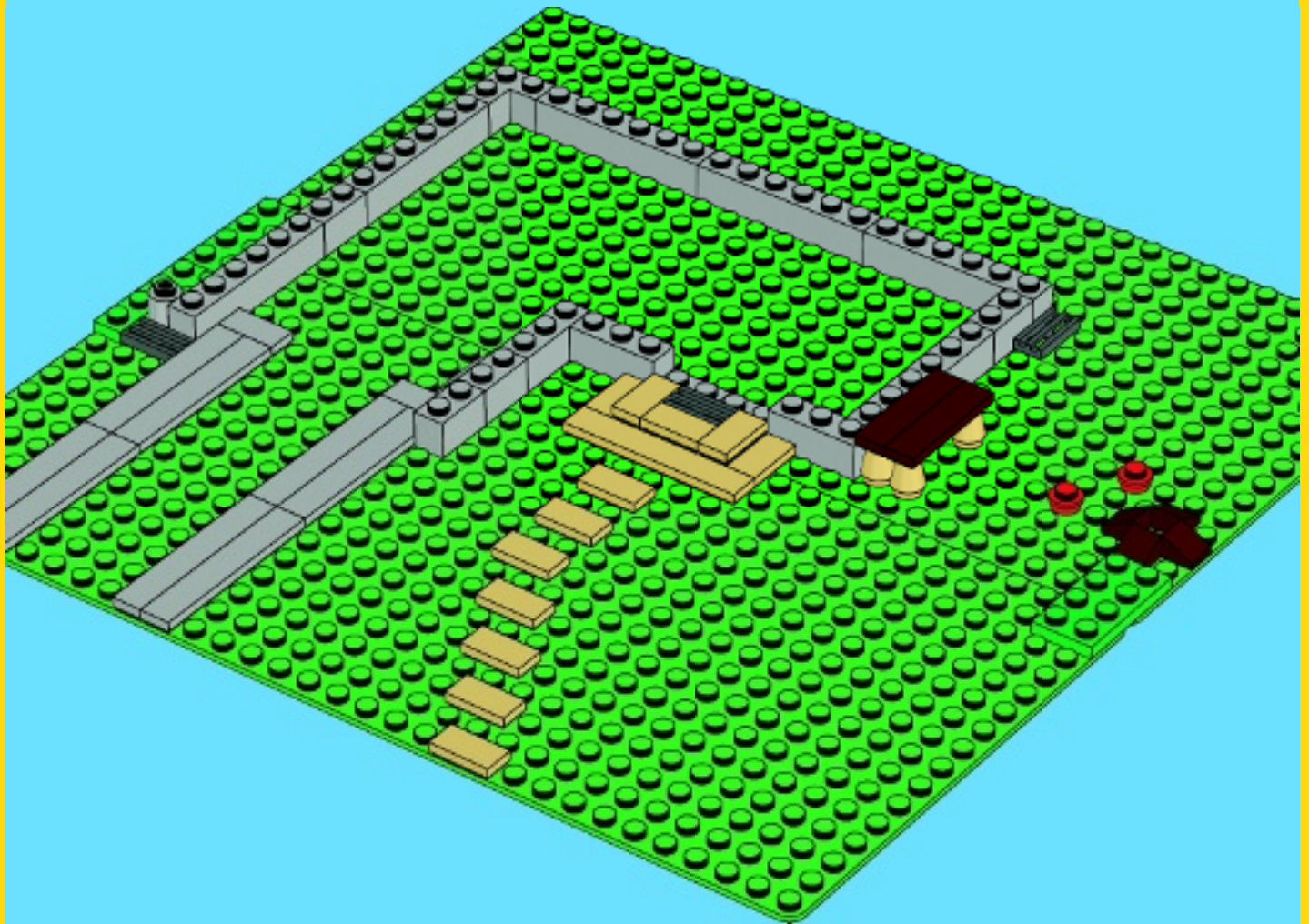

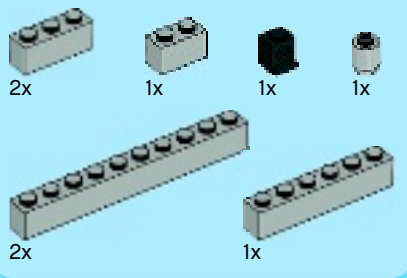

10

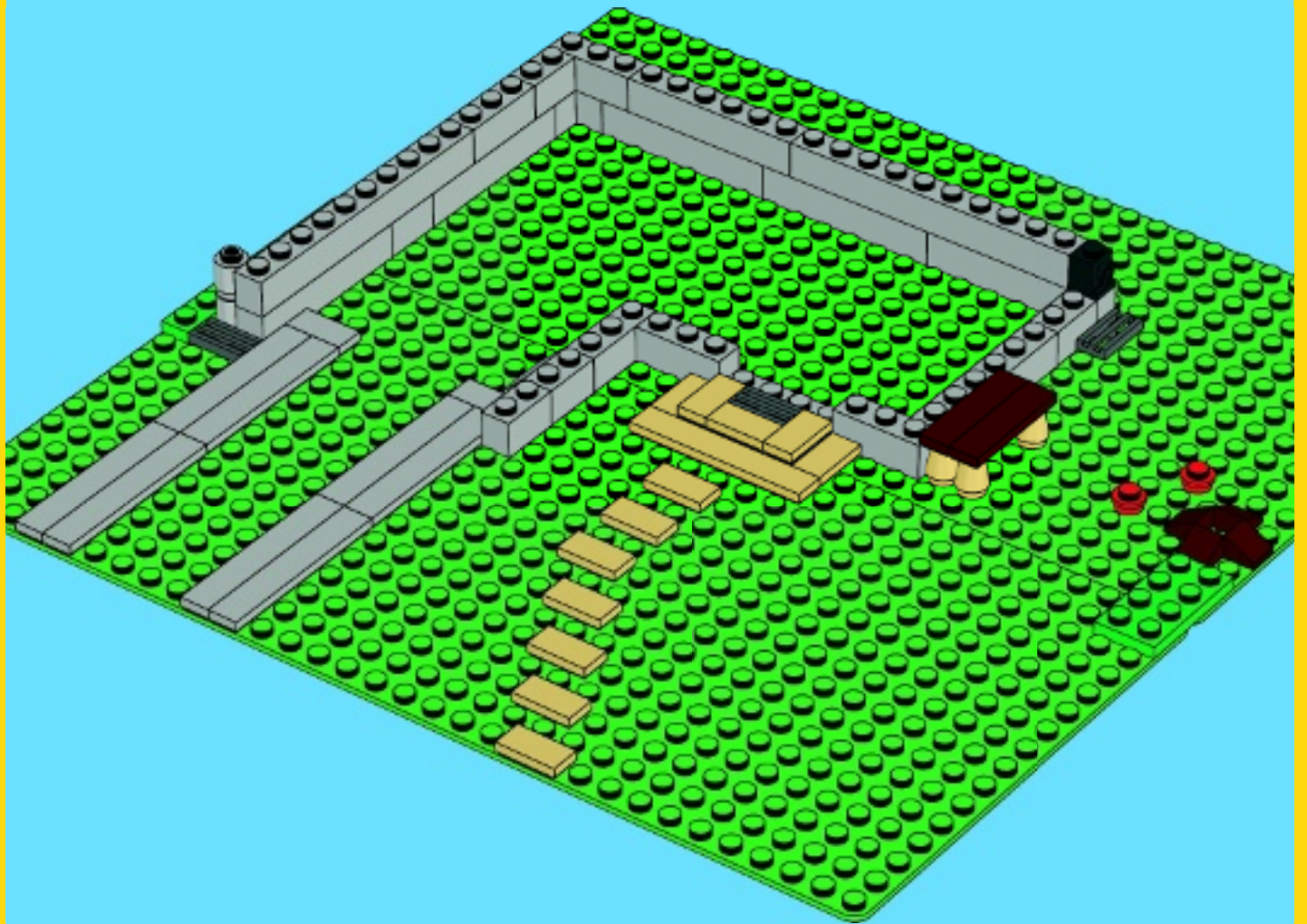

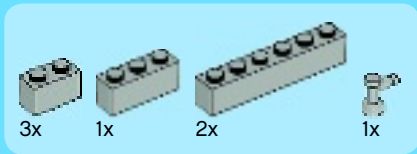

11

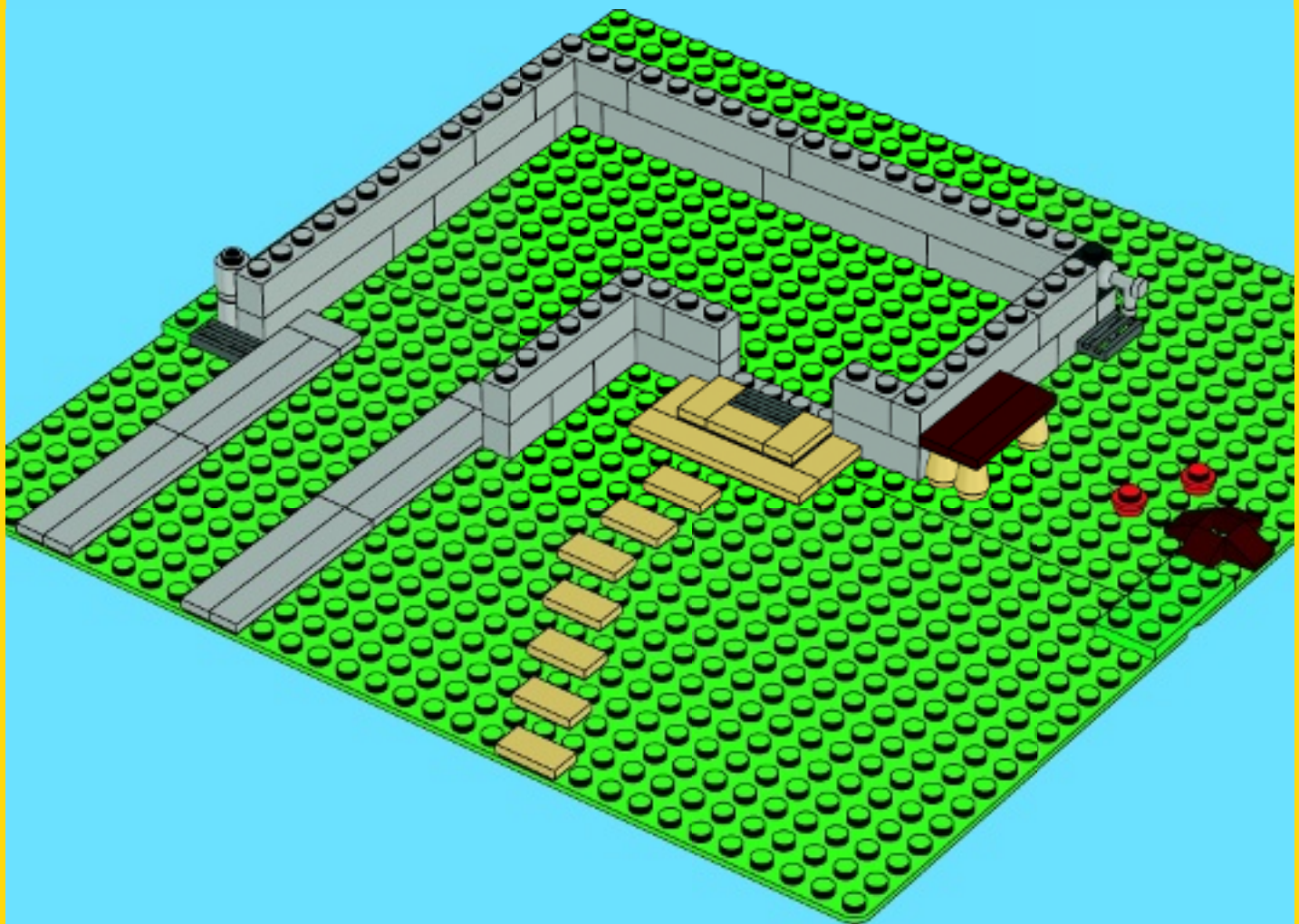

- 4x
- 1x
- 4x
- 2x
- 1x
- 1x

12

1

2

3

1

2

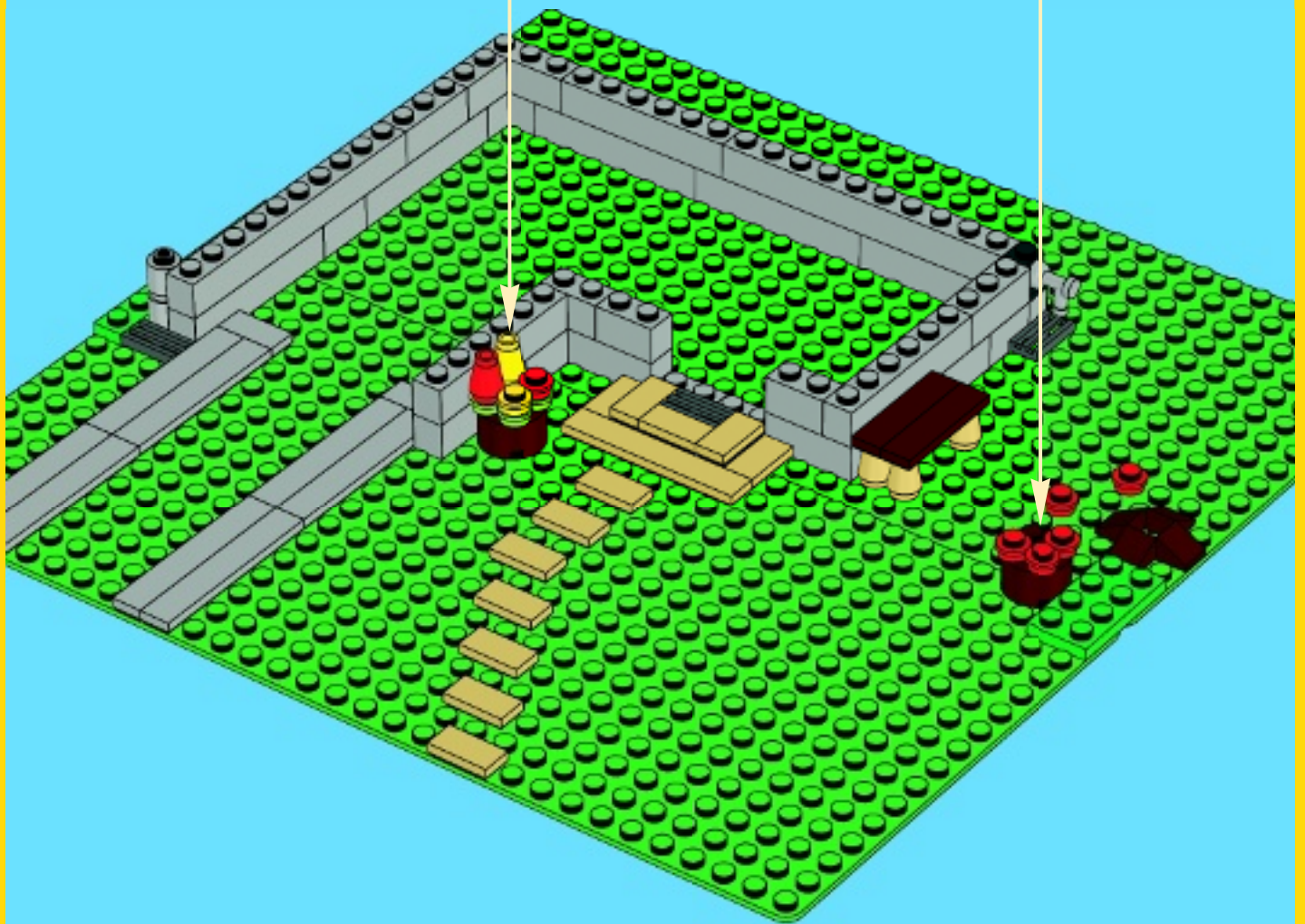



13

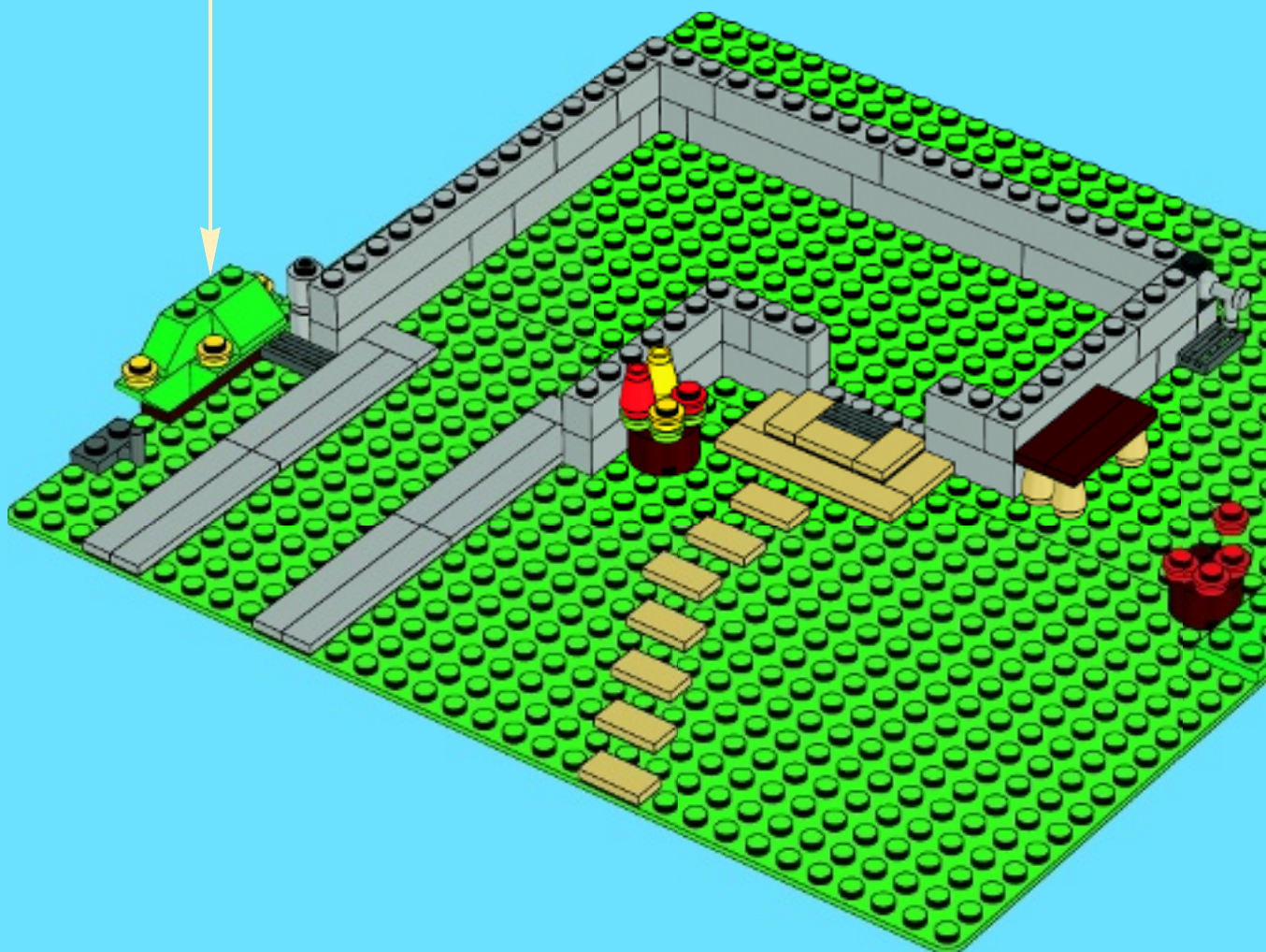
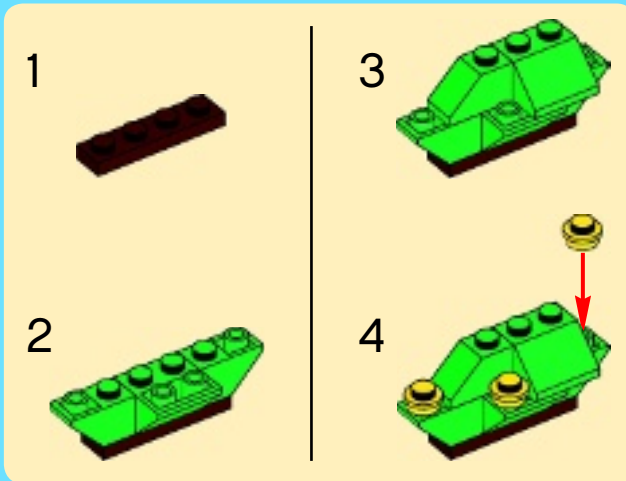



14

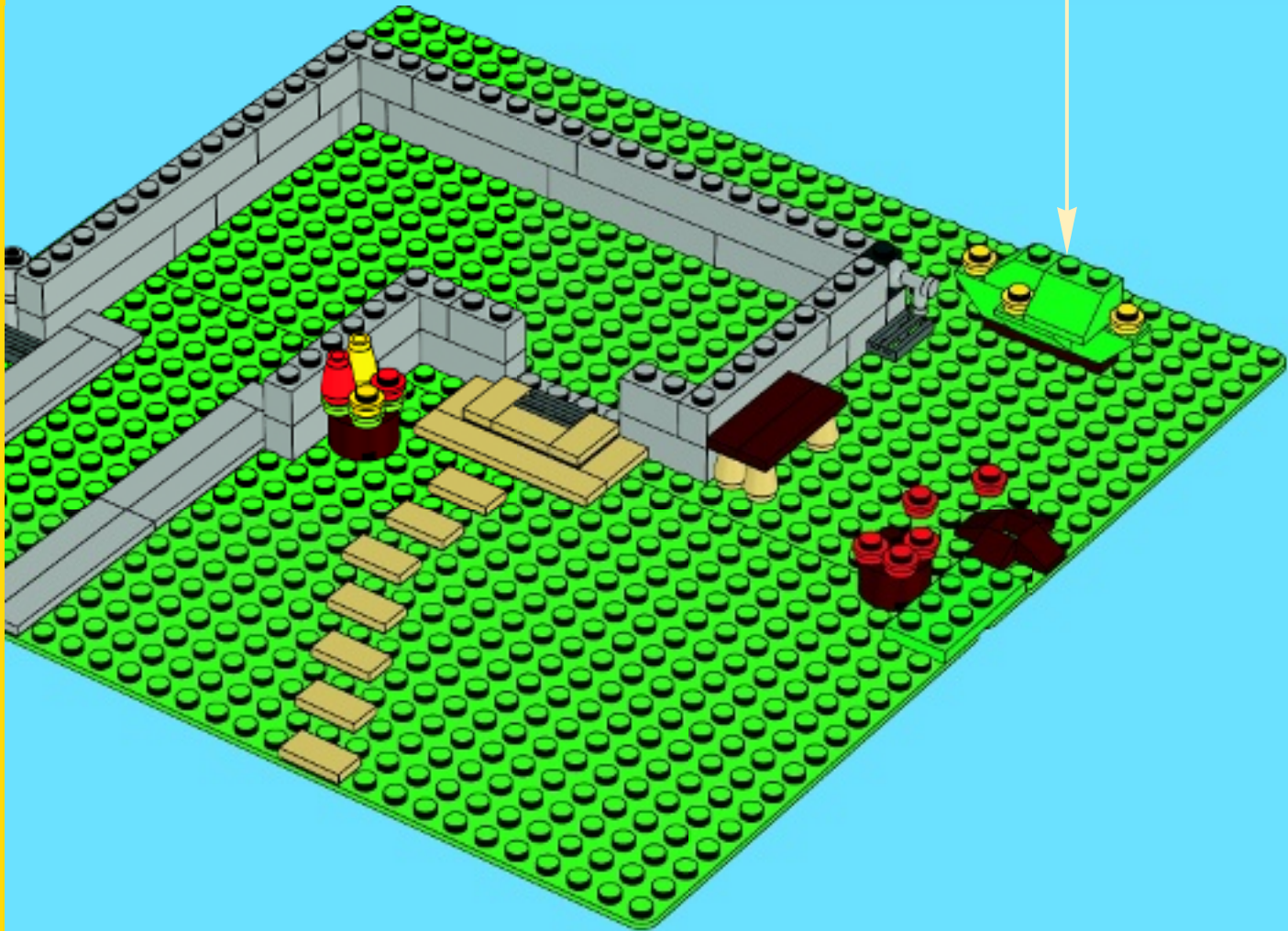
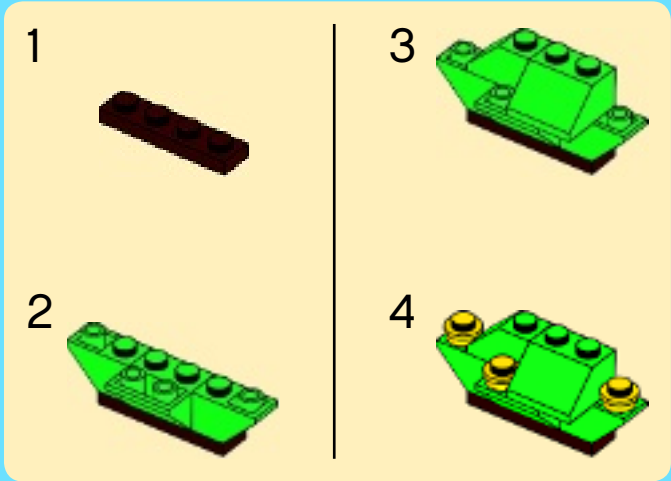

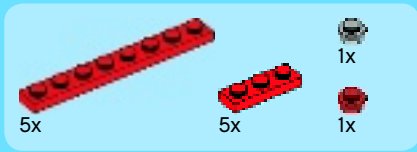

15

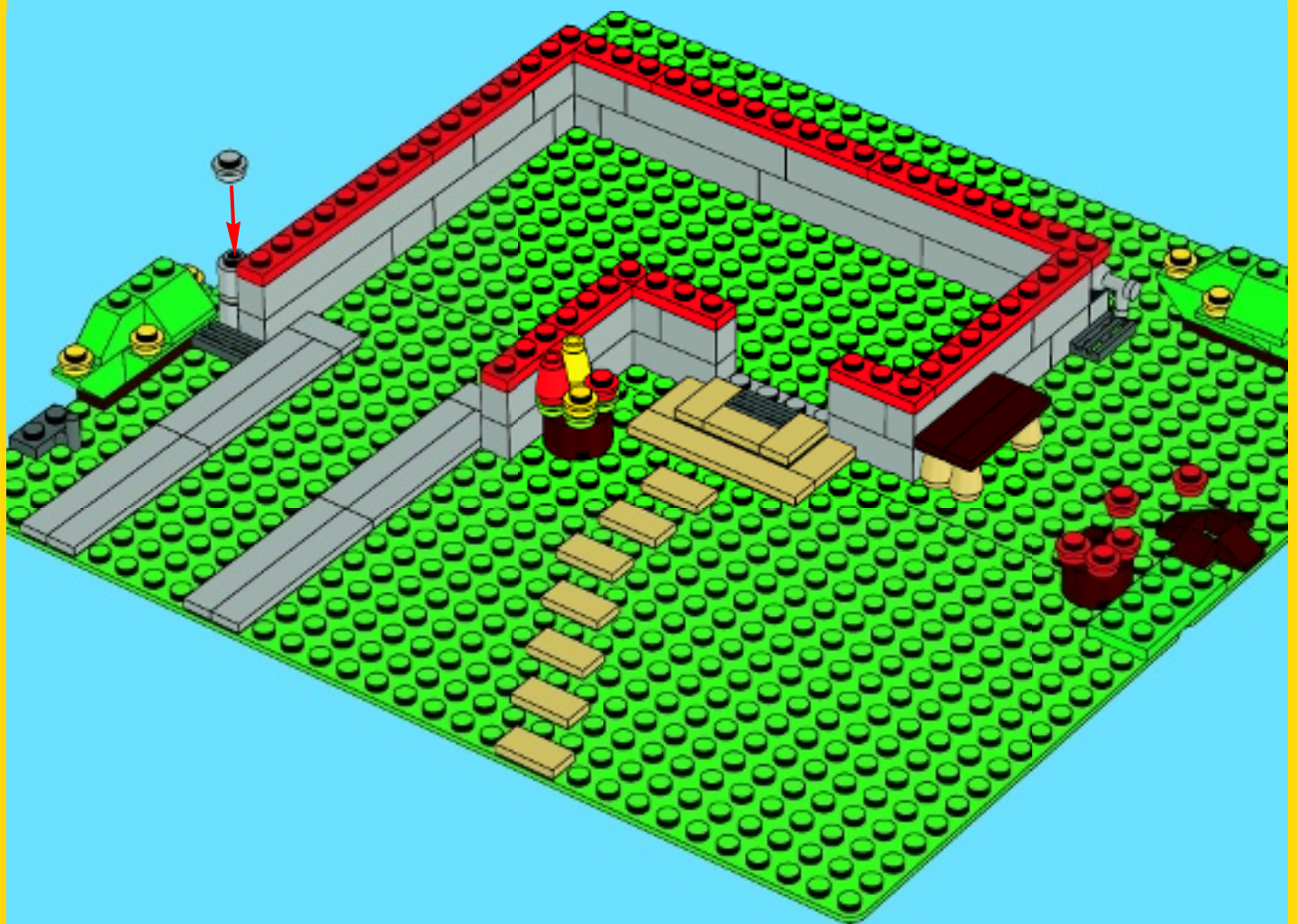

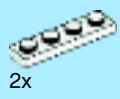

2x



1x



1x

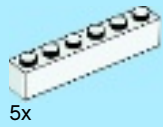

5x

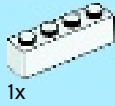

1x

16

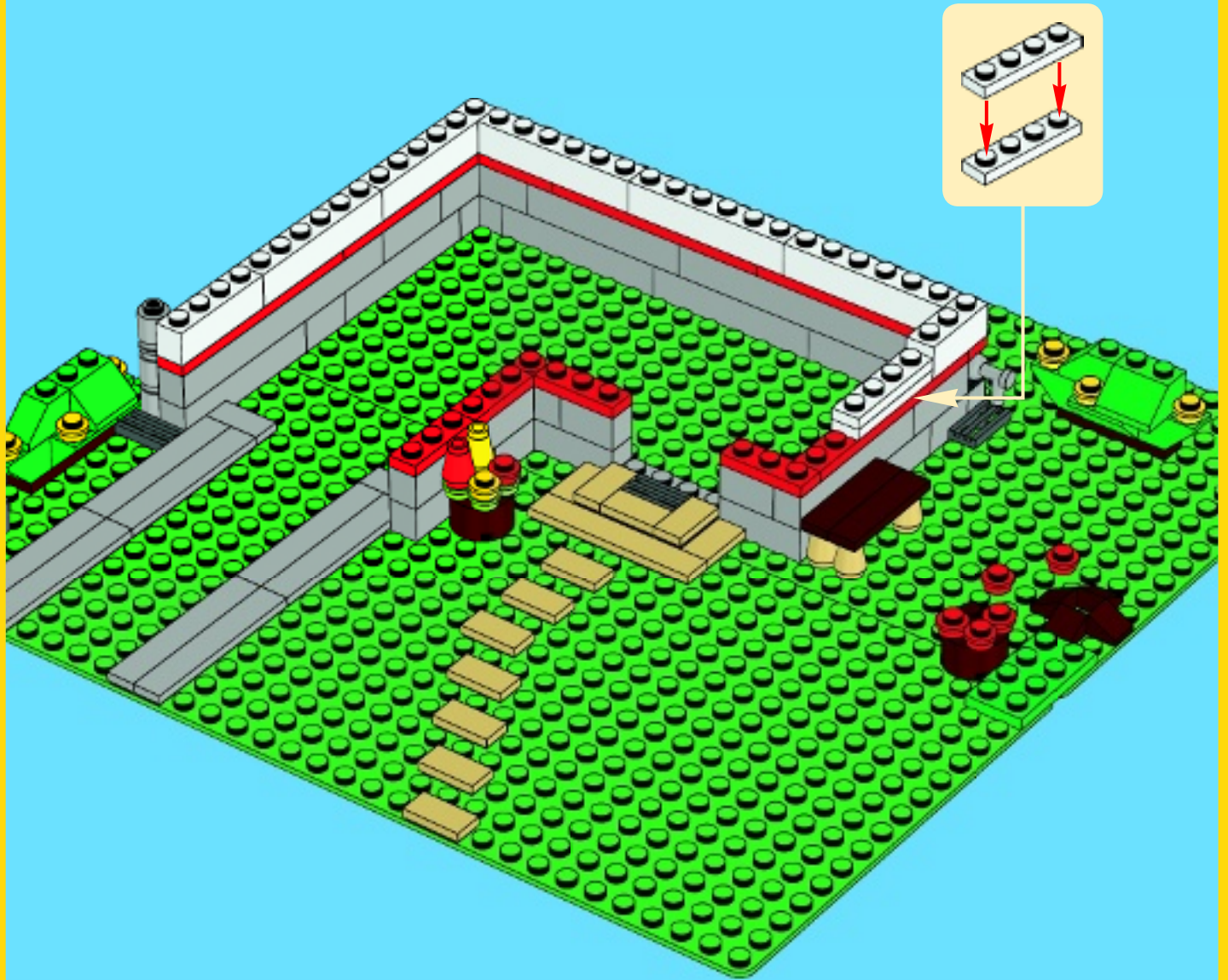

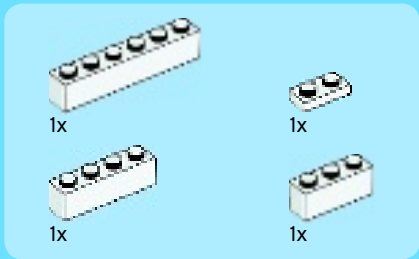

17

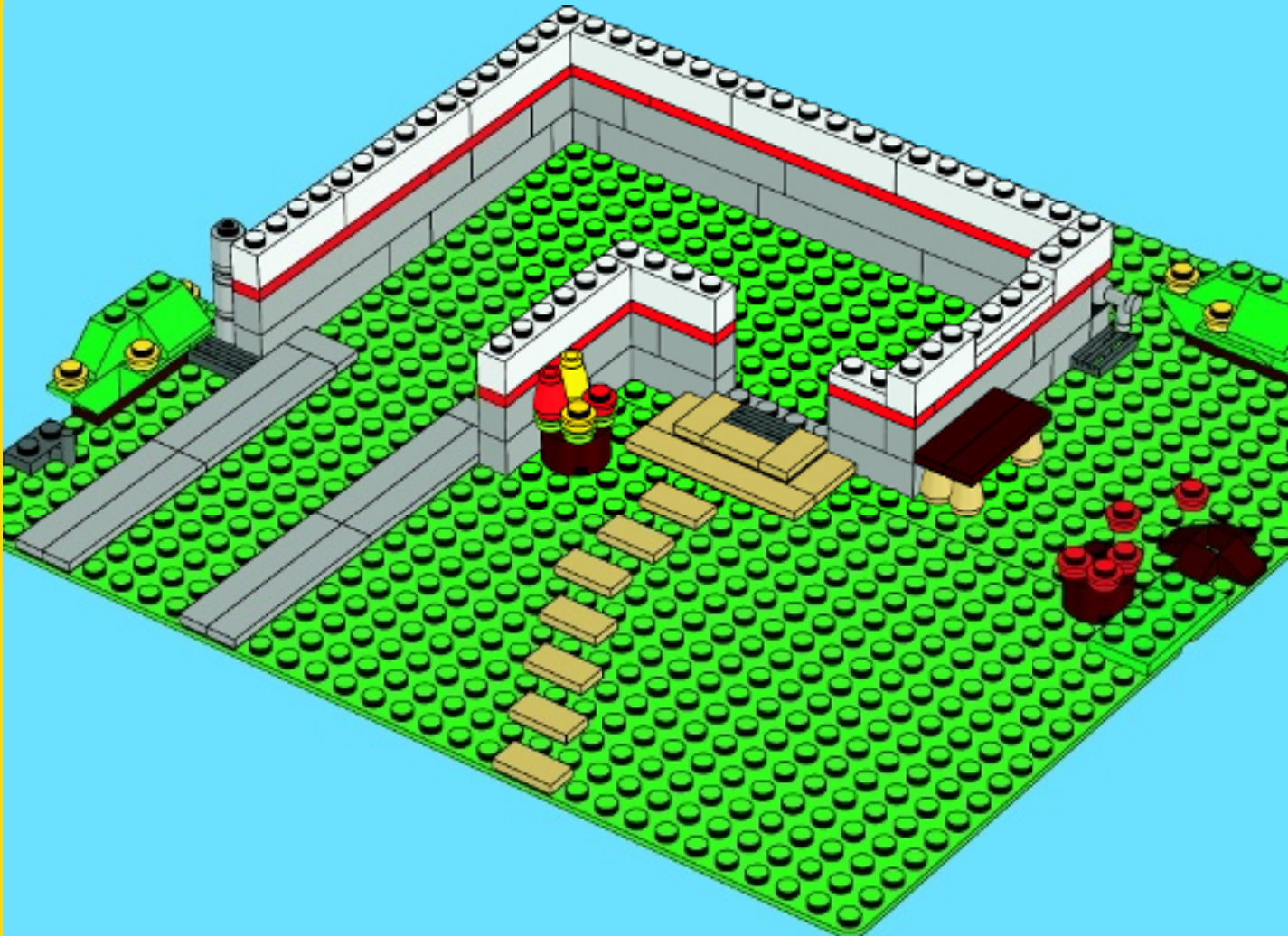

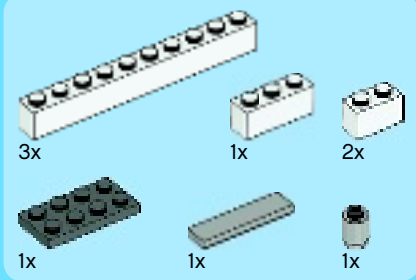

18

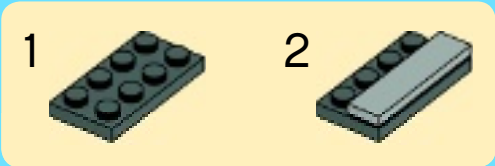

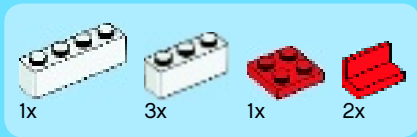

19

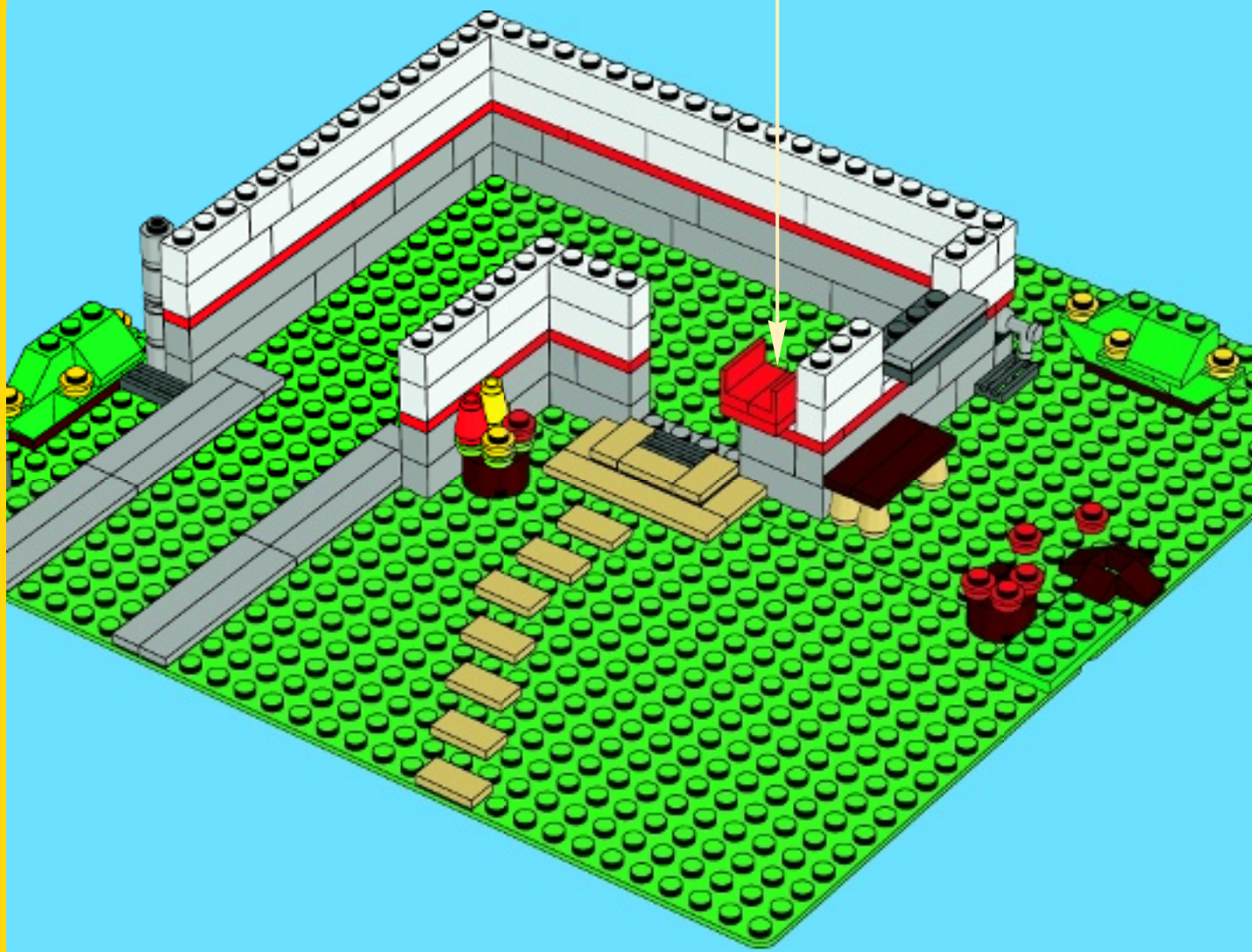
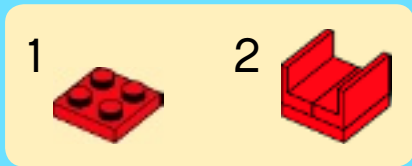

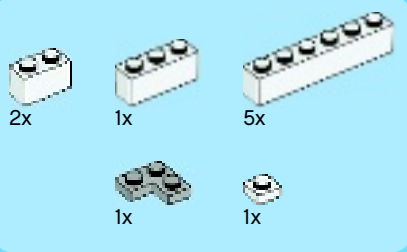

20

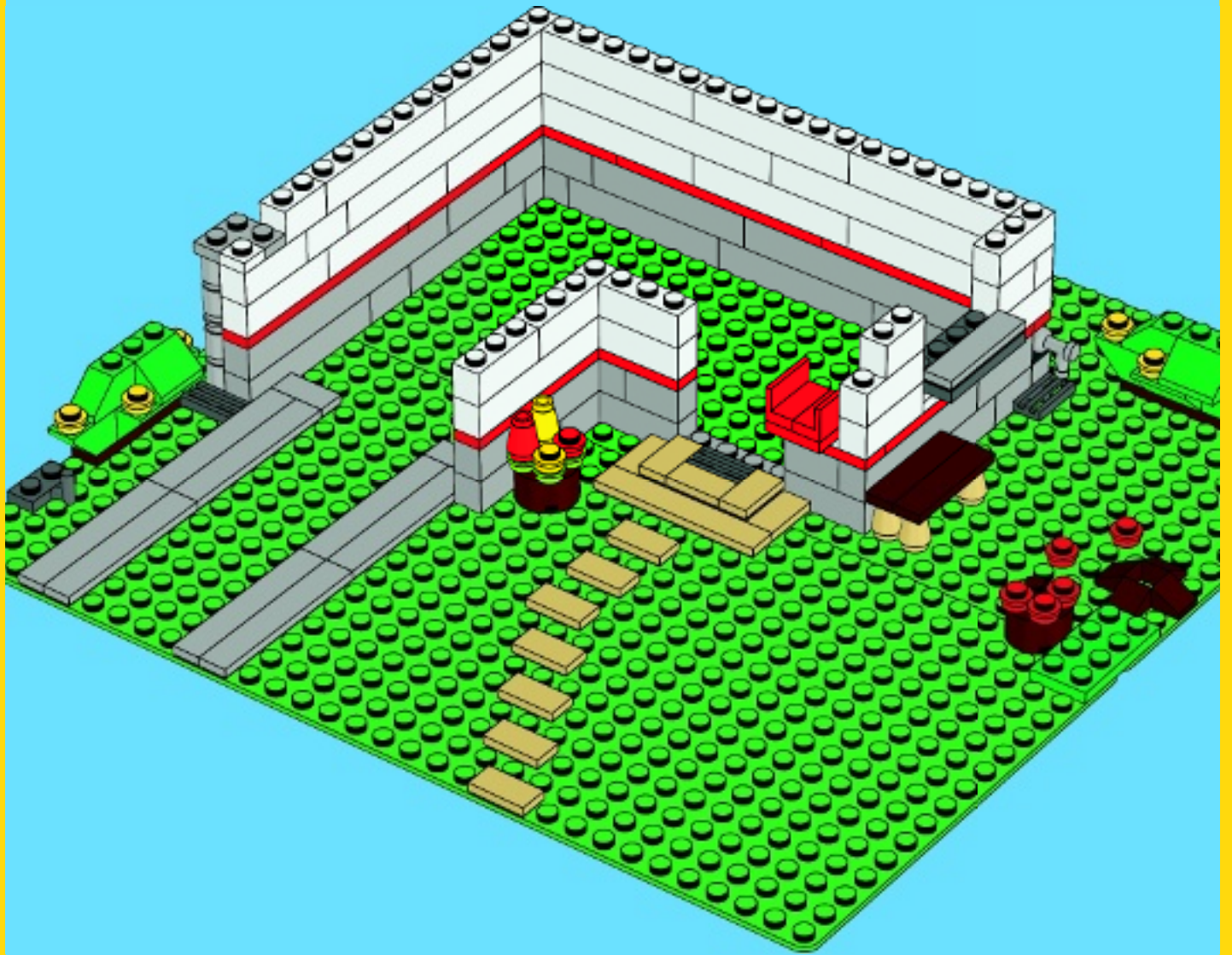

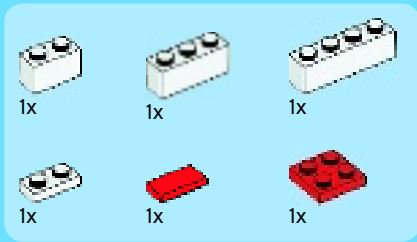

21

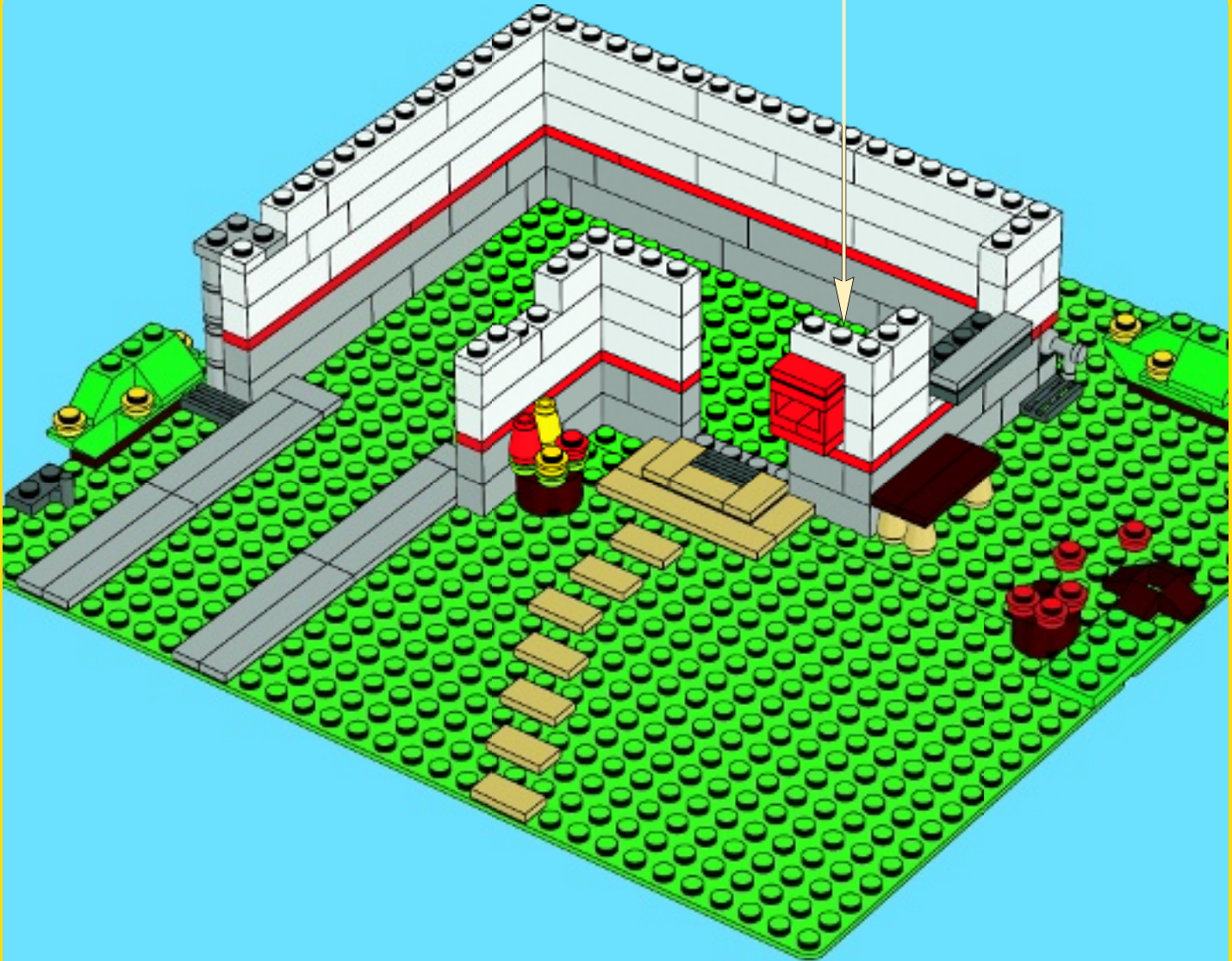
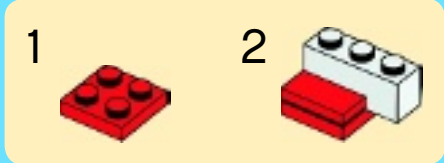

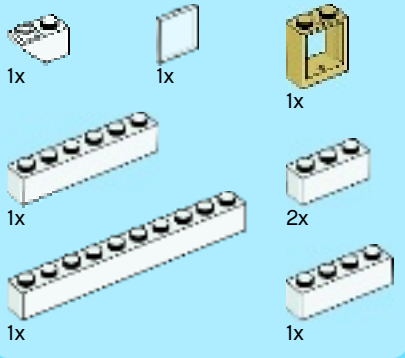

22

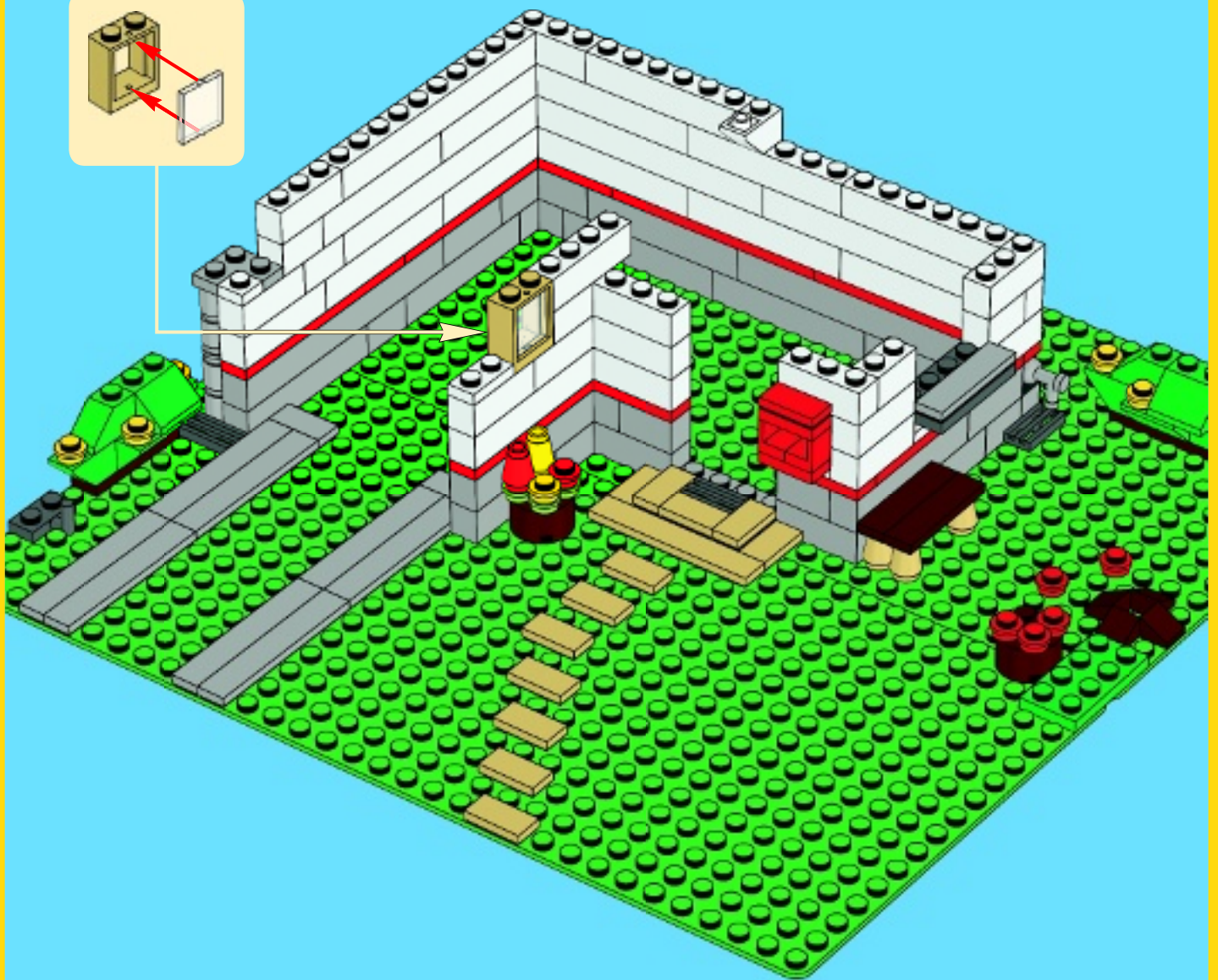
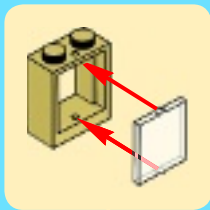

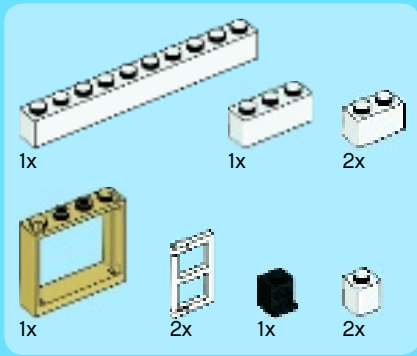

23

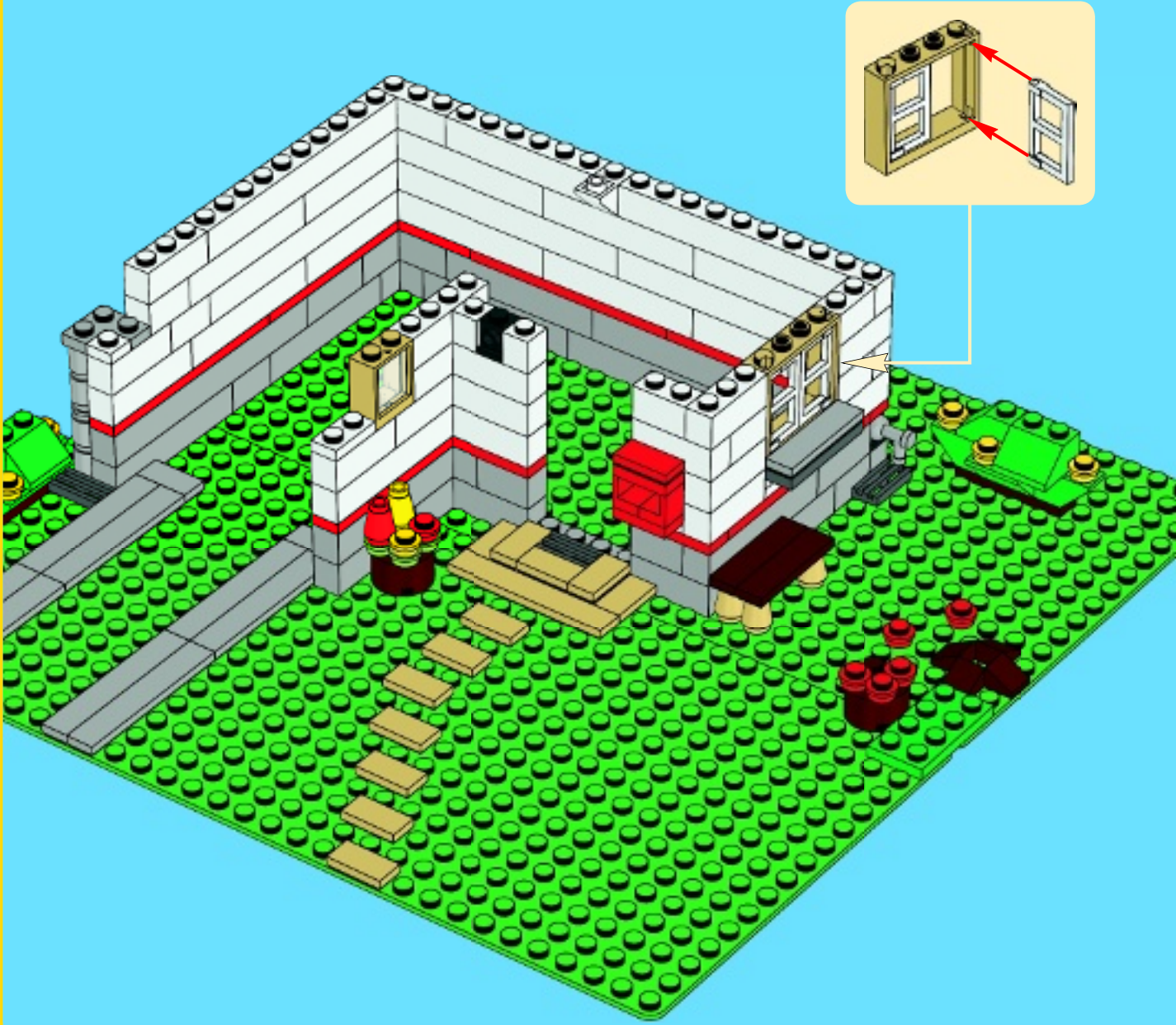

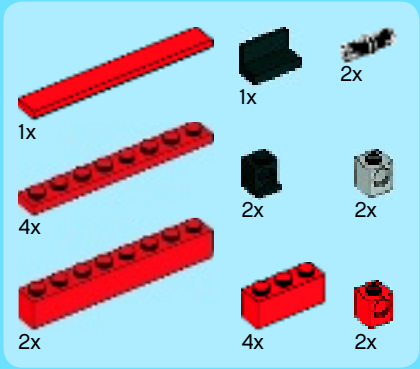
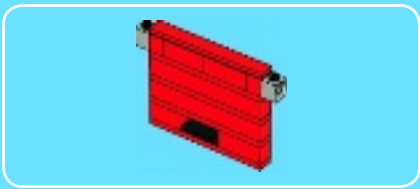

24

1



2

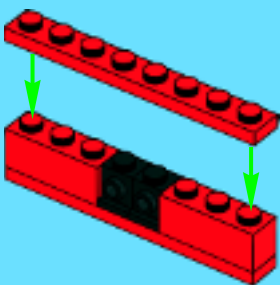

3

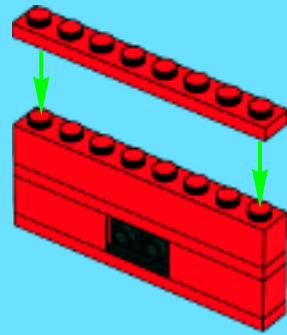

4

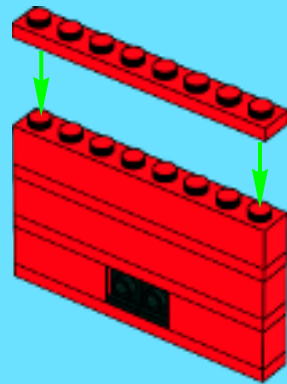

5

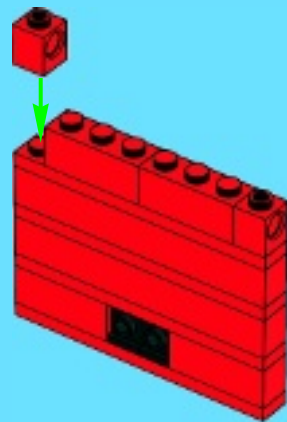

6

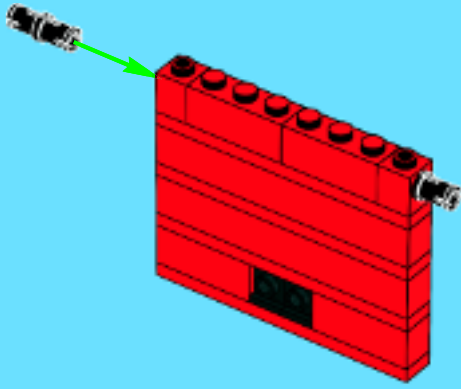

7

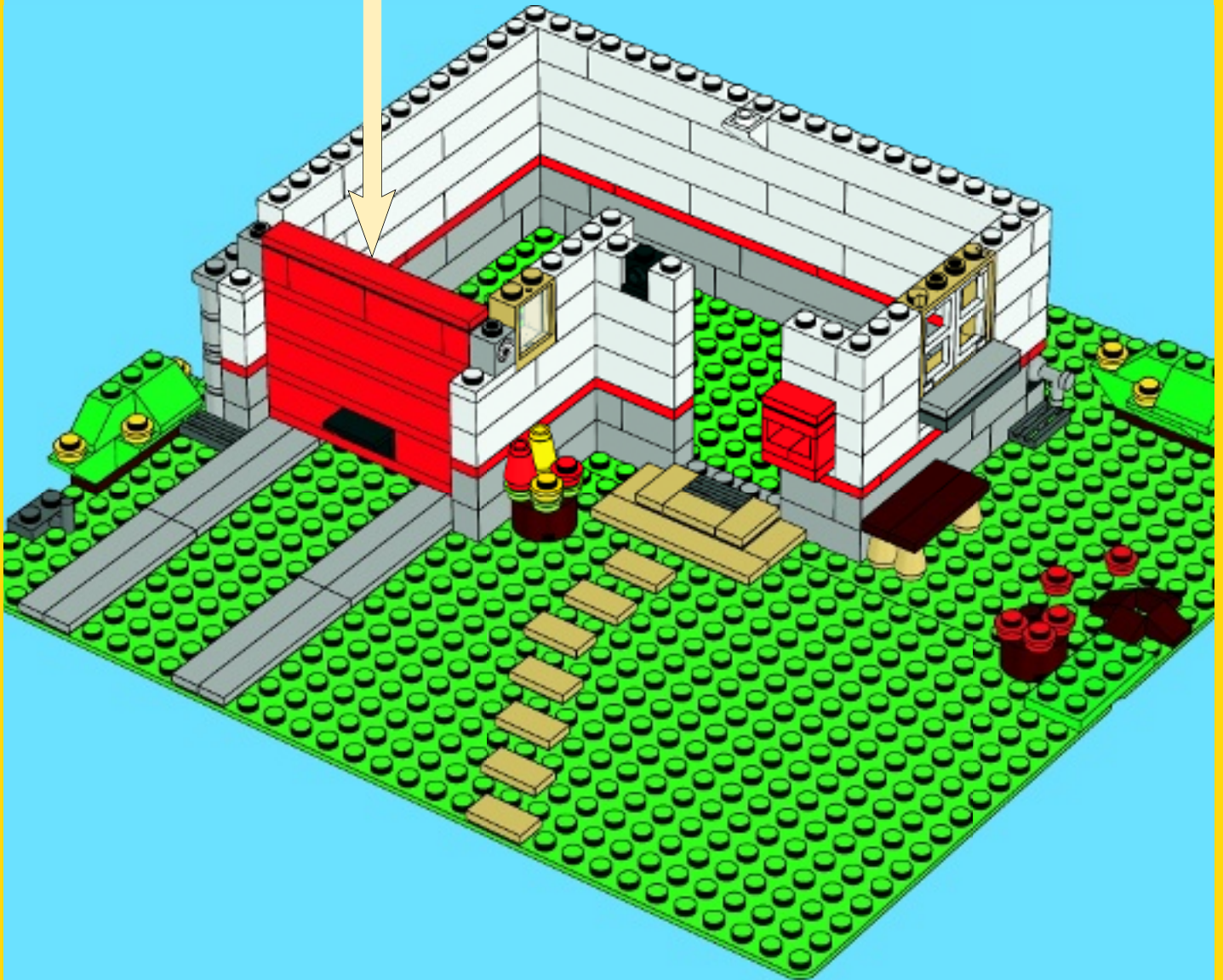
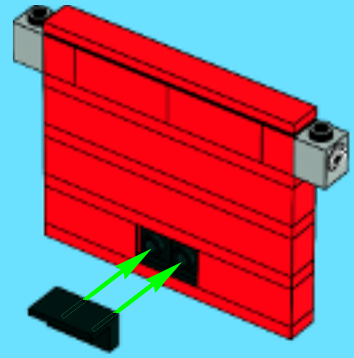



2x



1x

25

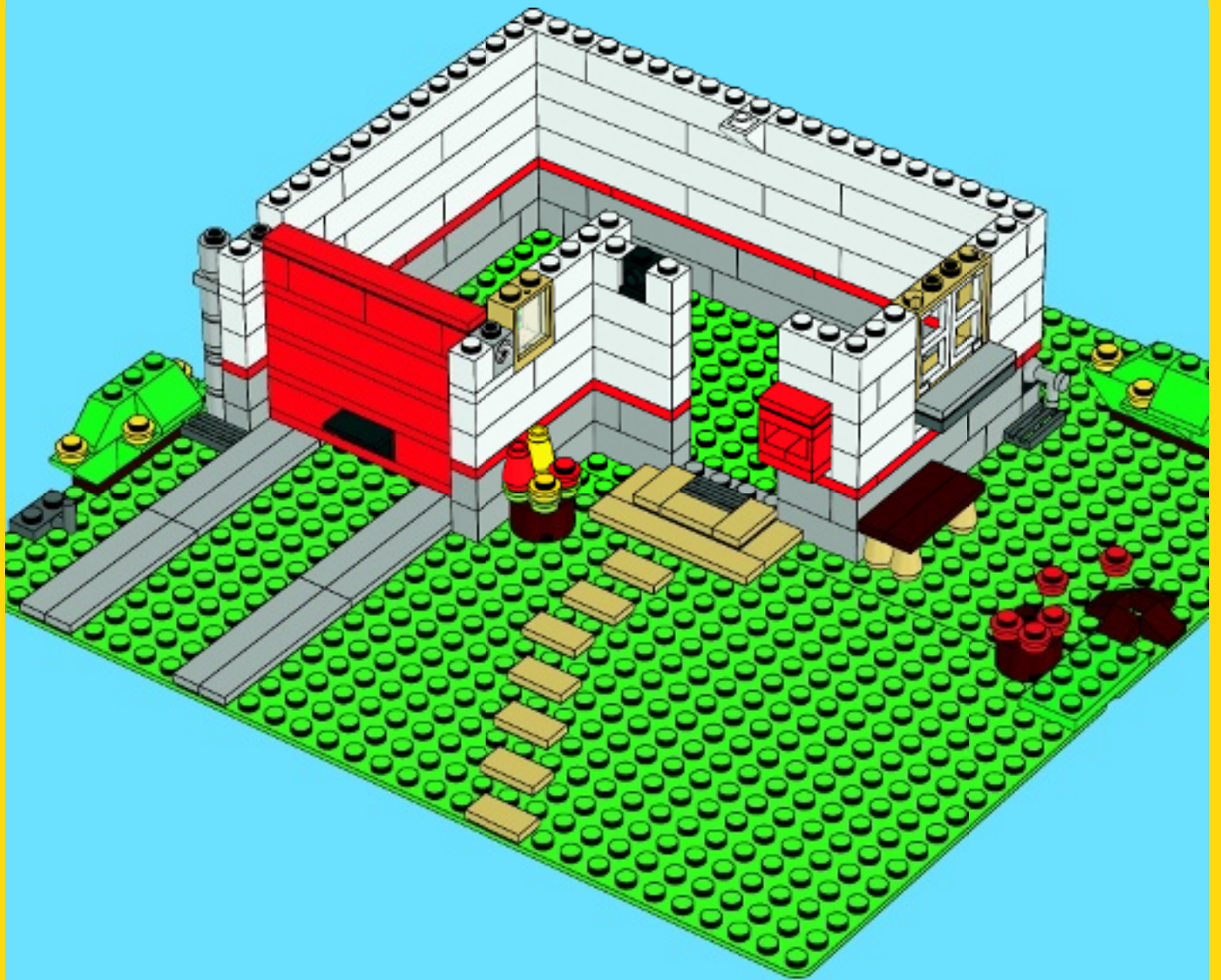



4x



1x

26

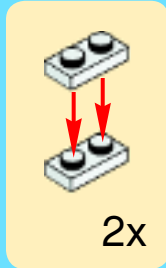

2x

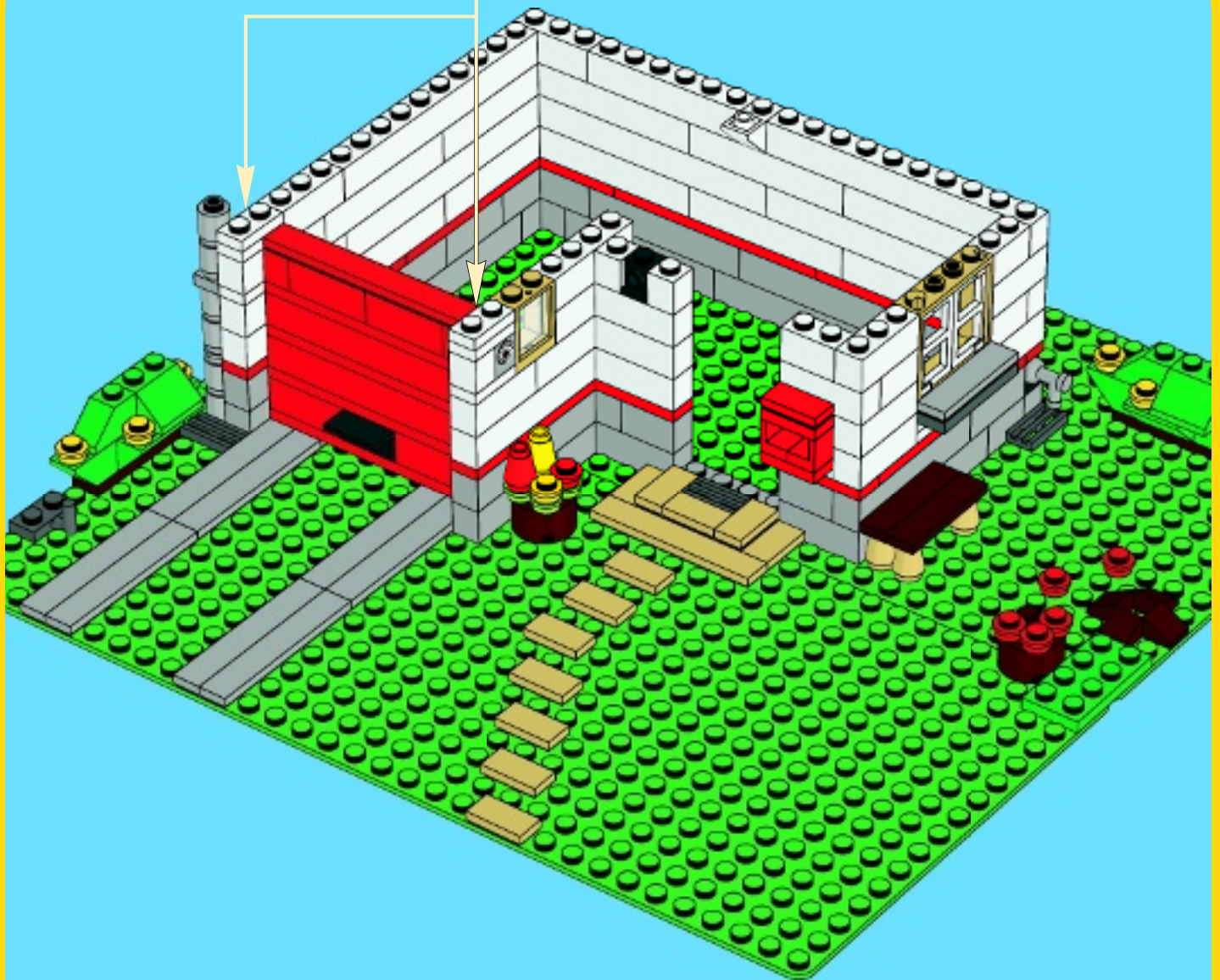

27

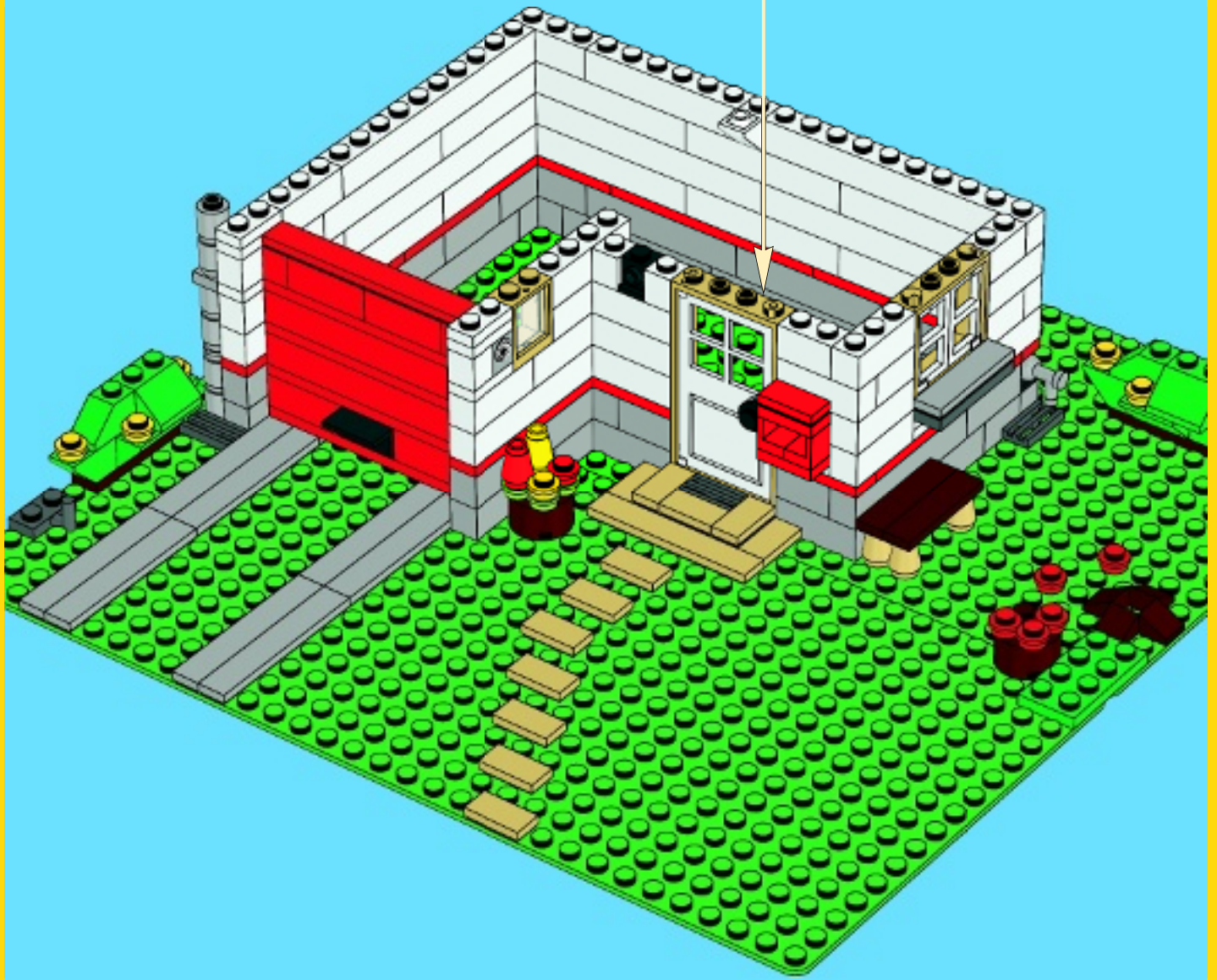
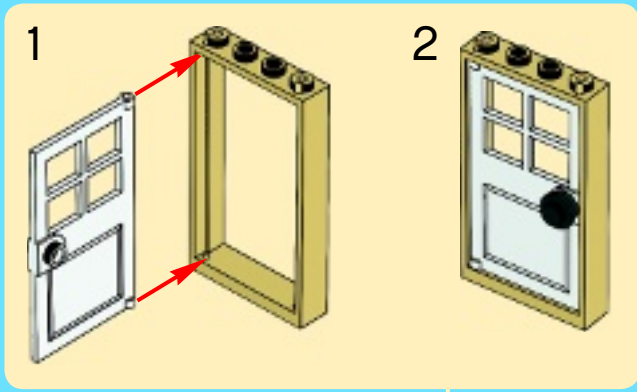
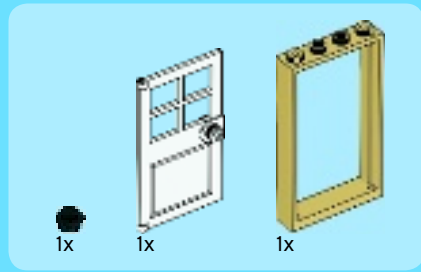

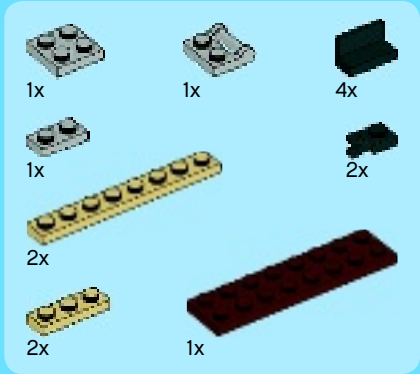

28

1

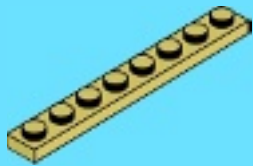

2



3



4



5

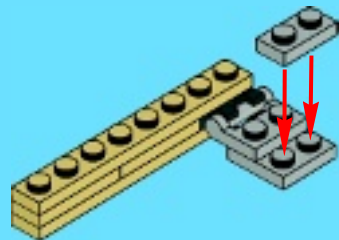

6

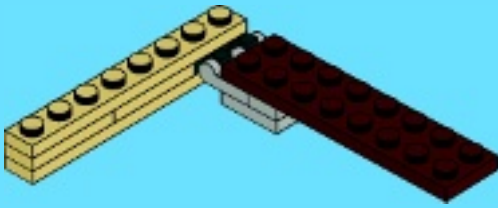

7

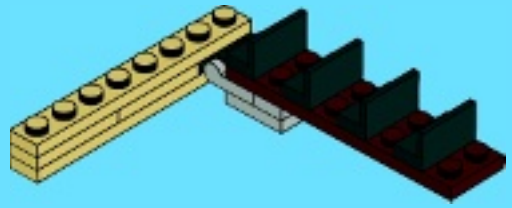

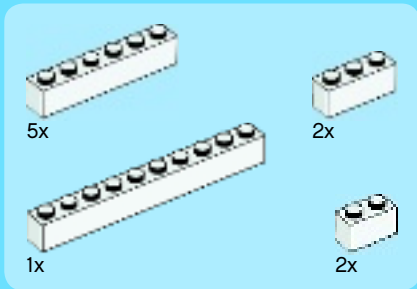

29

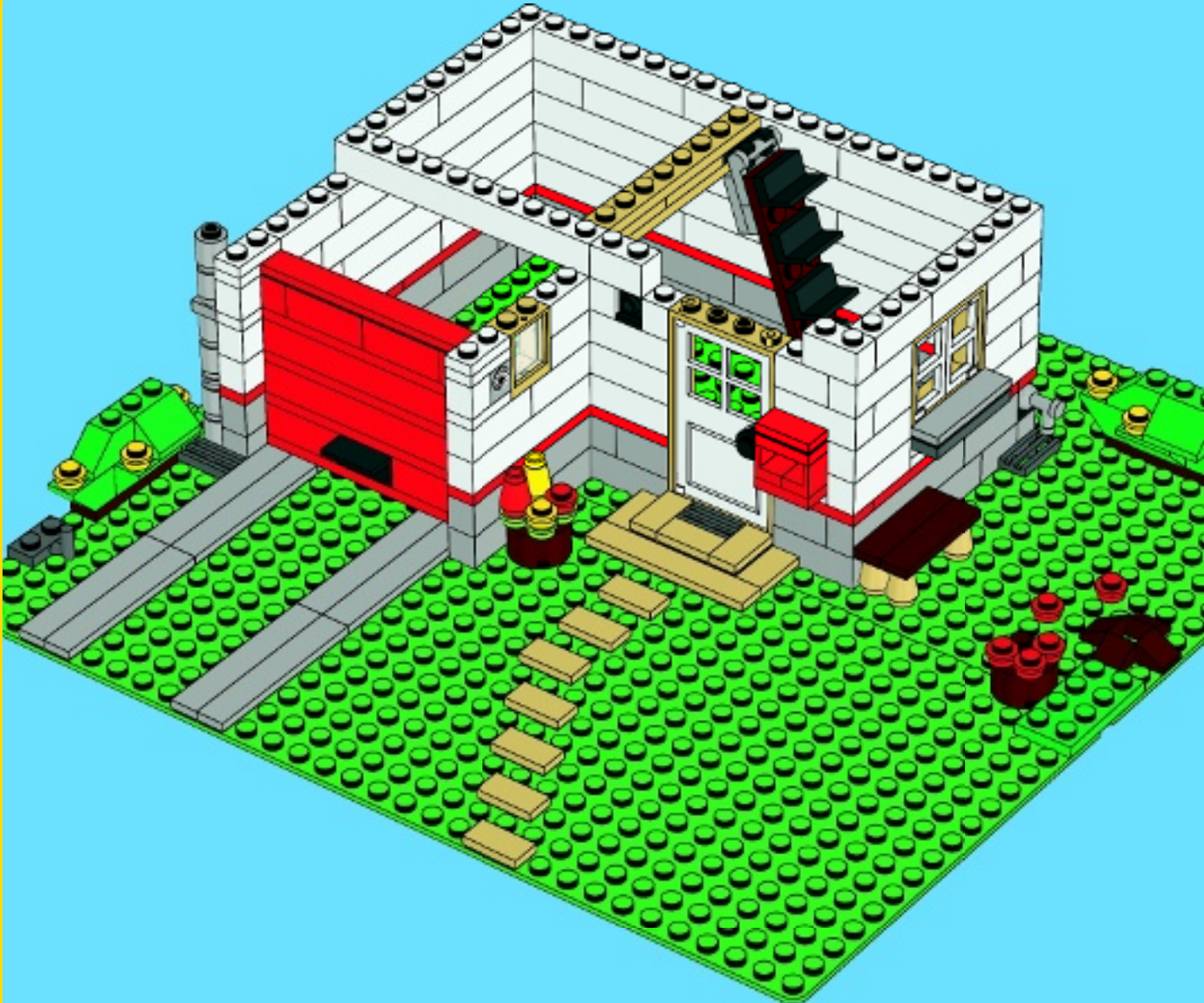



1x



1x



2x



1x

30

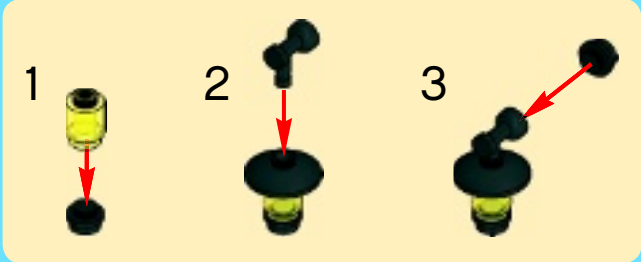

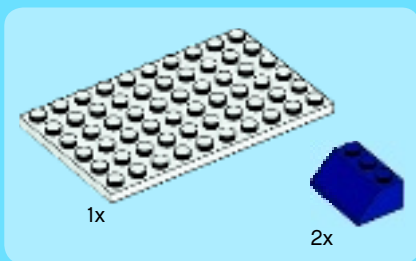

31

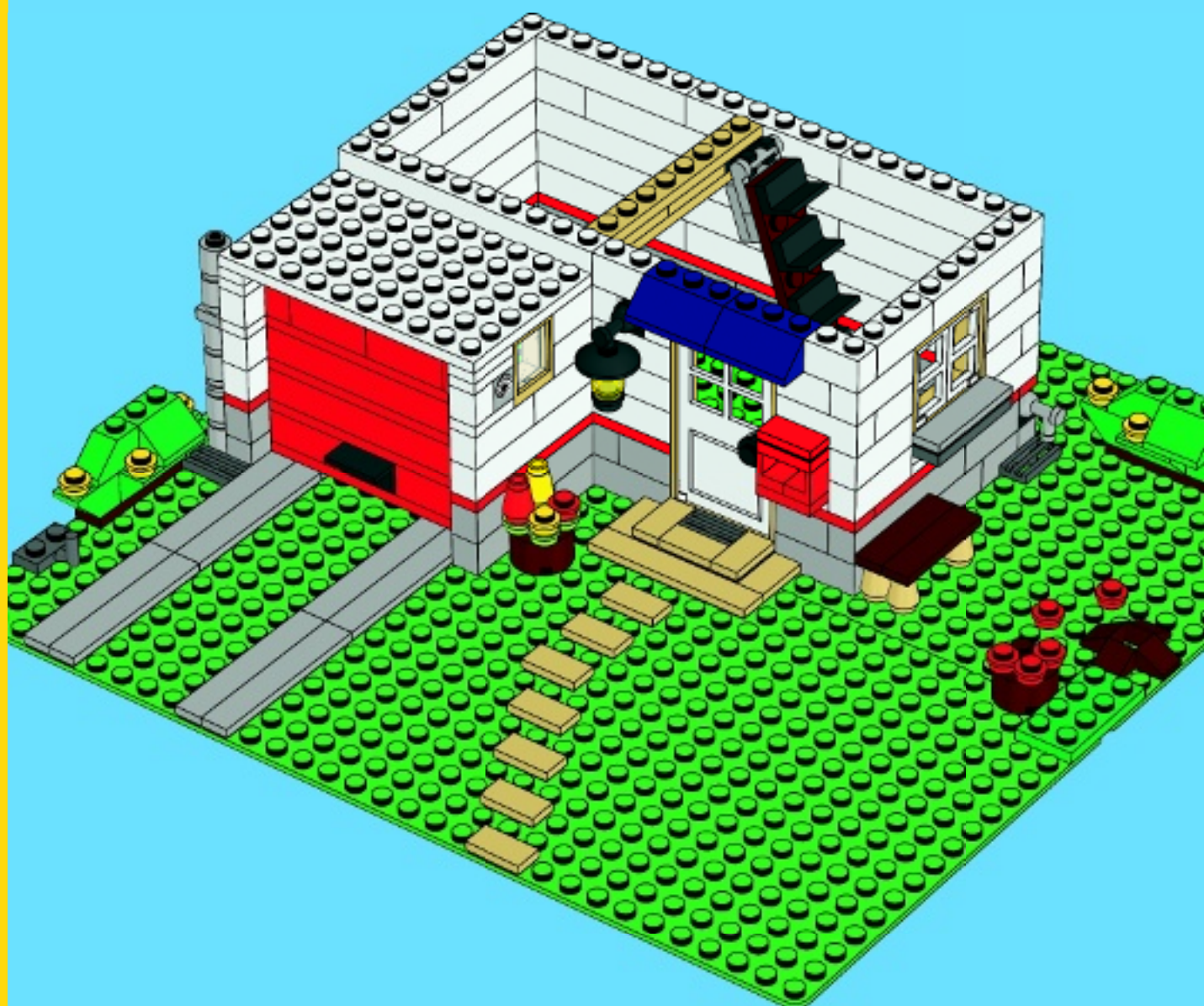

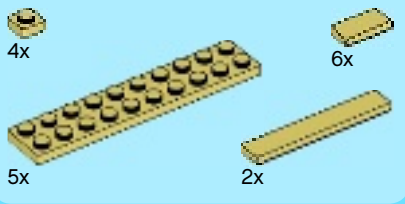

32

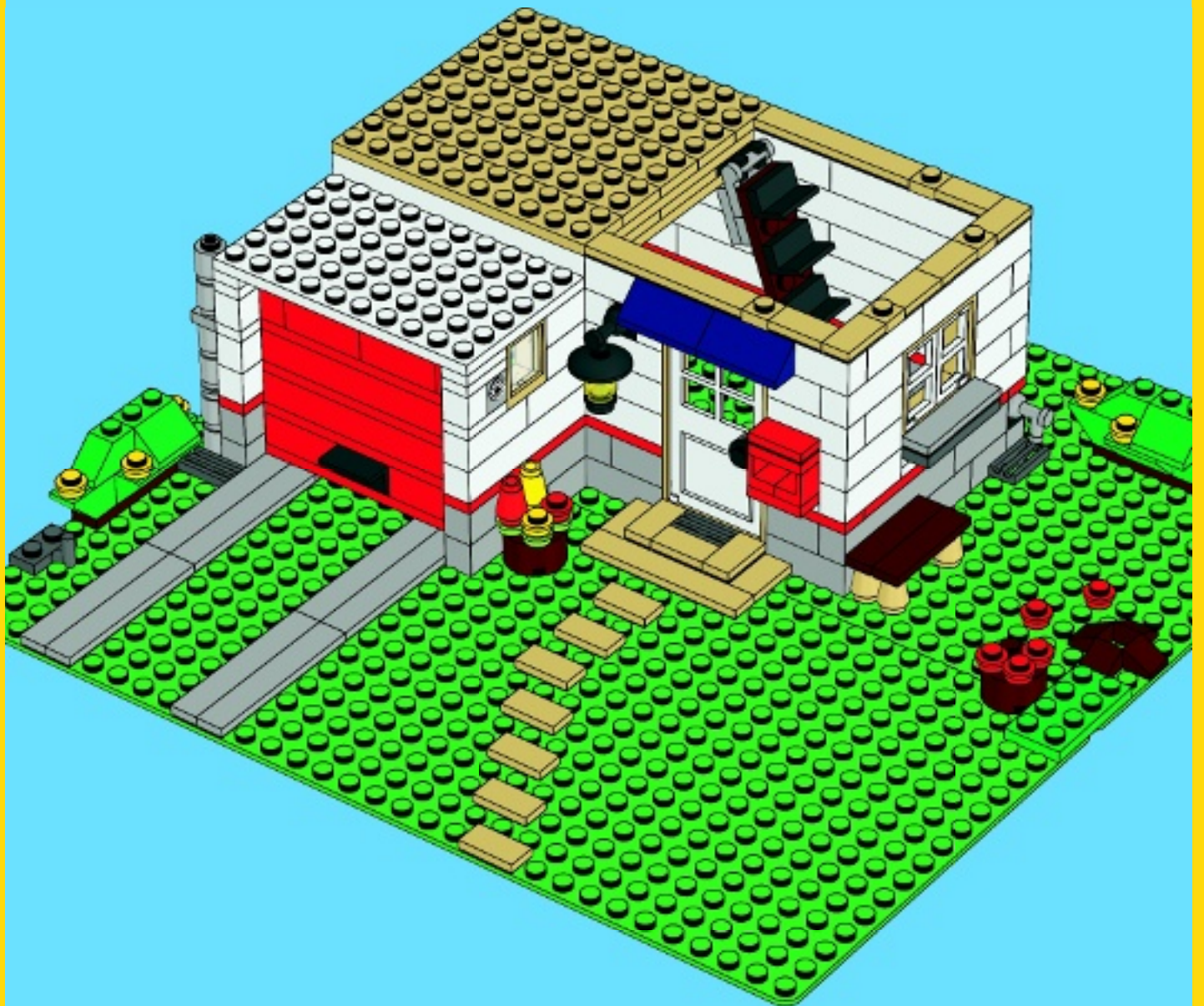

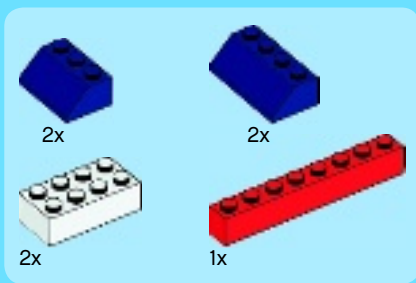

33

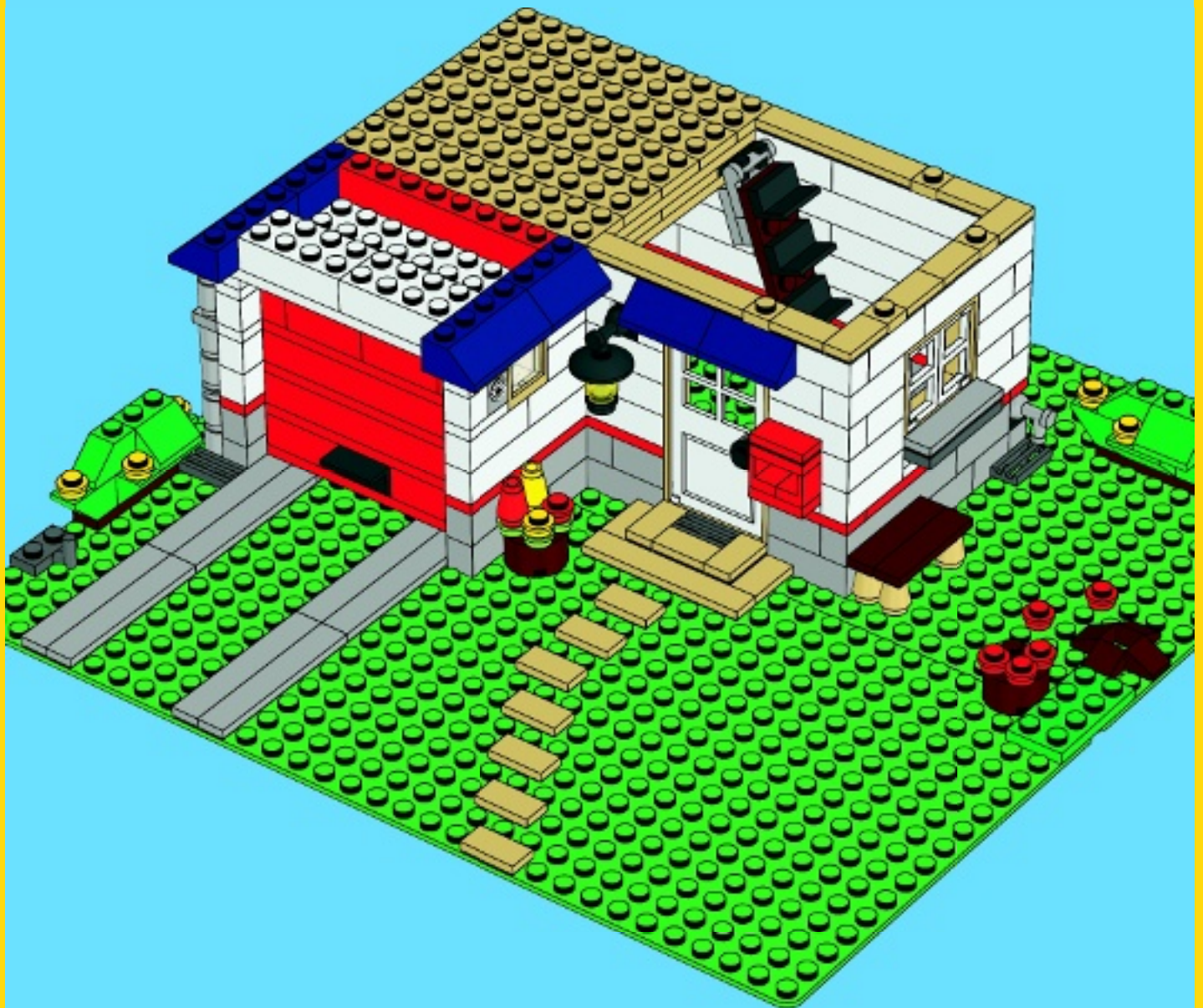

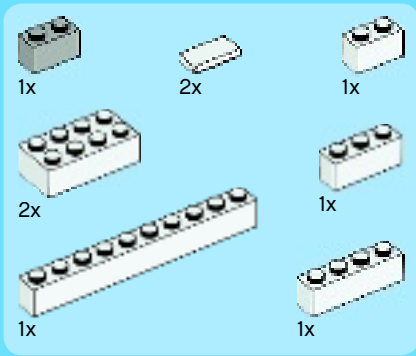

34

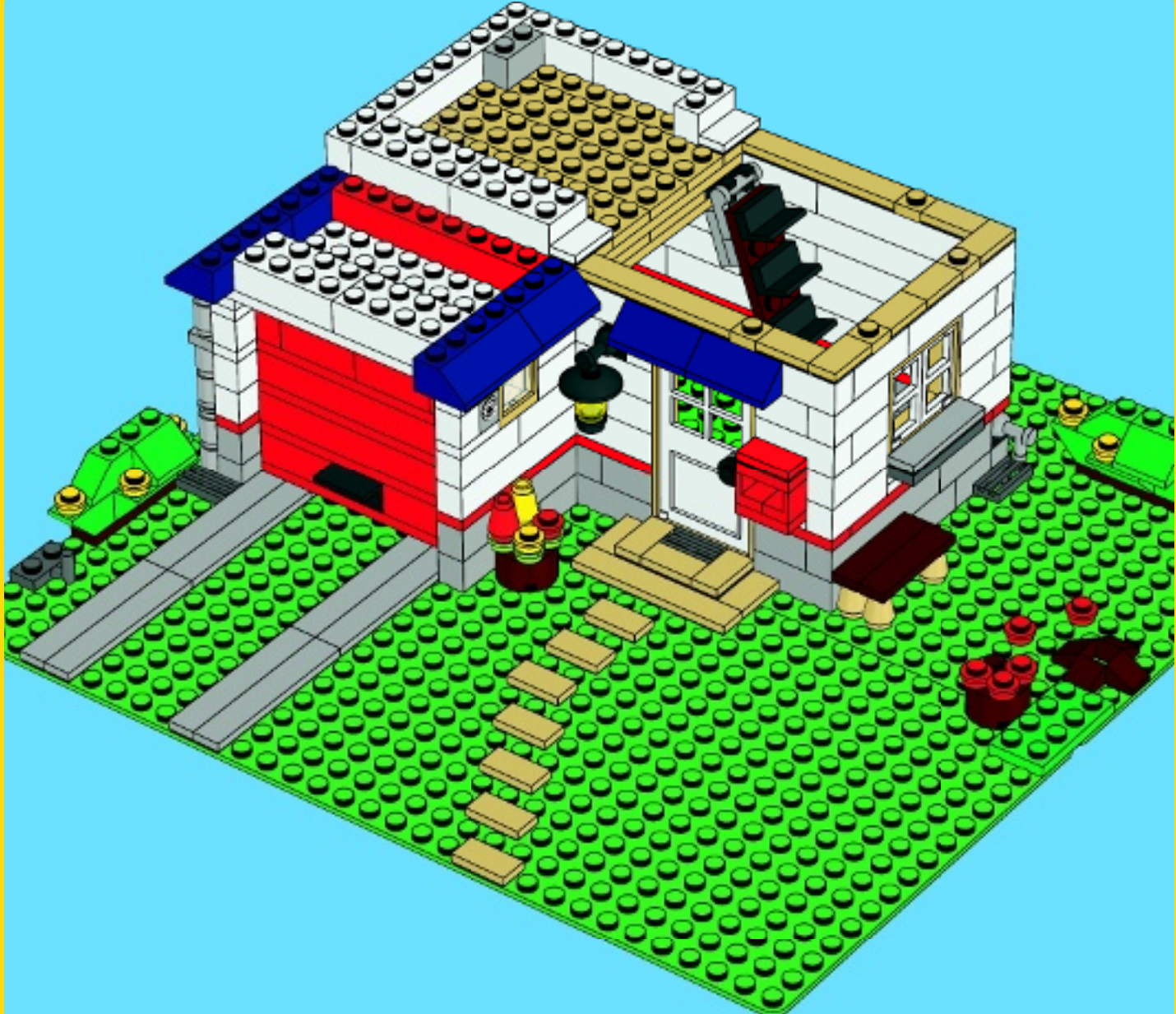

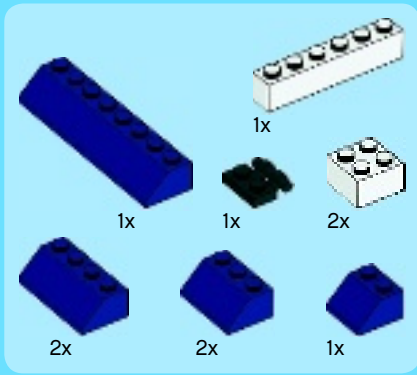

35





2x



2x



1x



1x

36

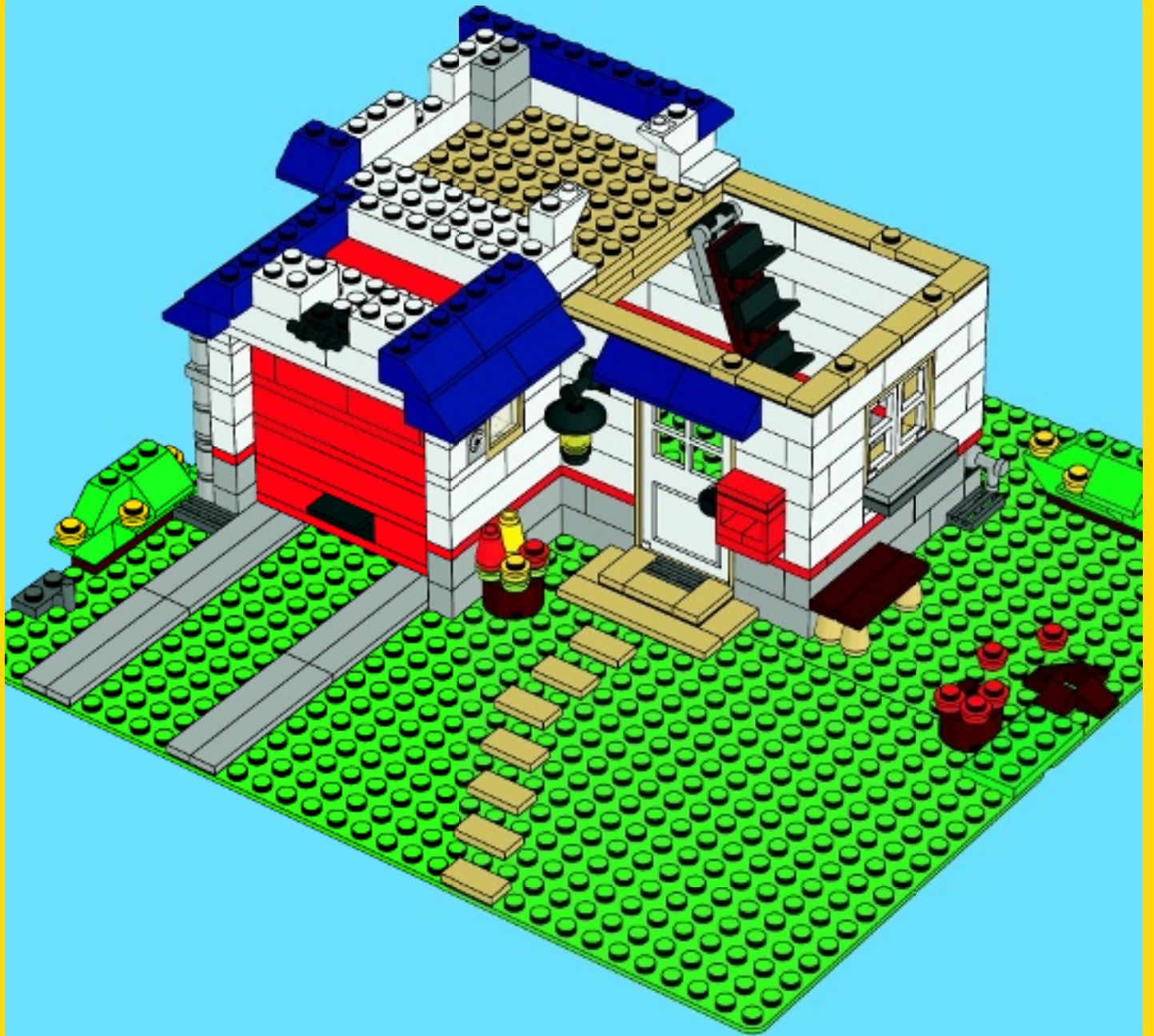



2x



2x



2x

37

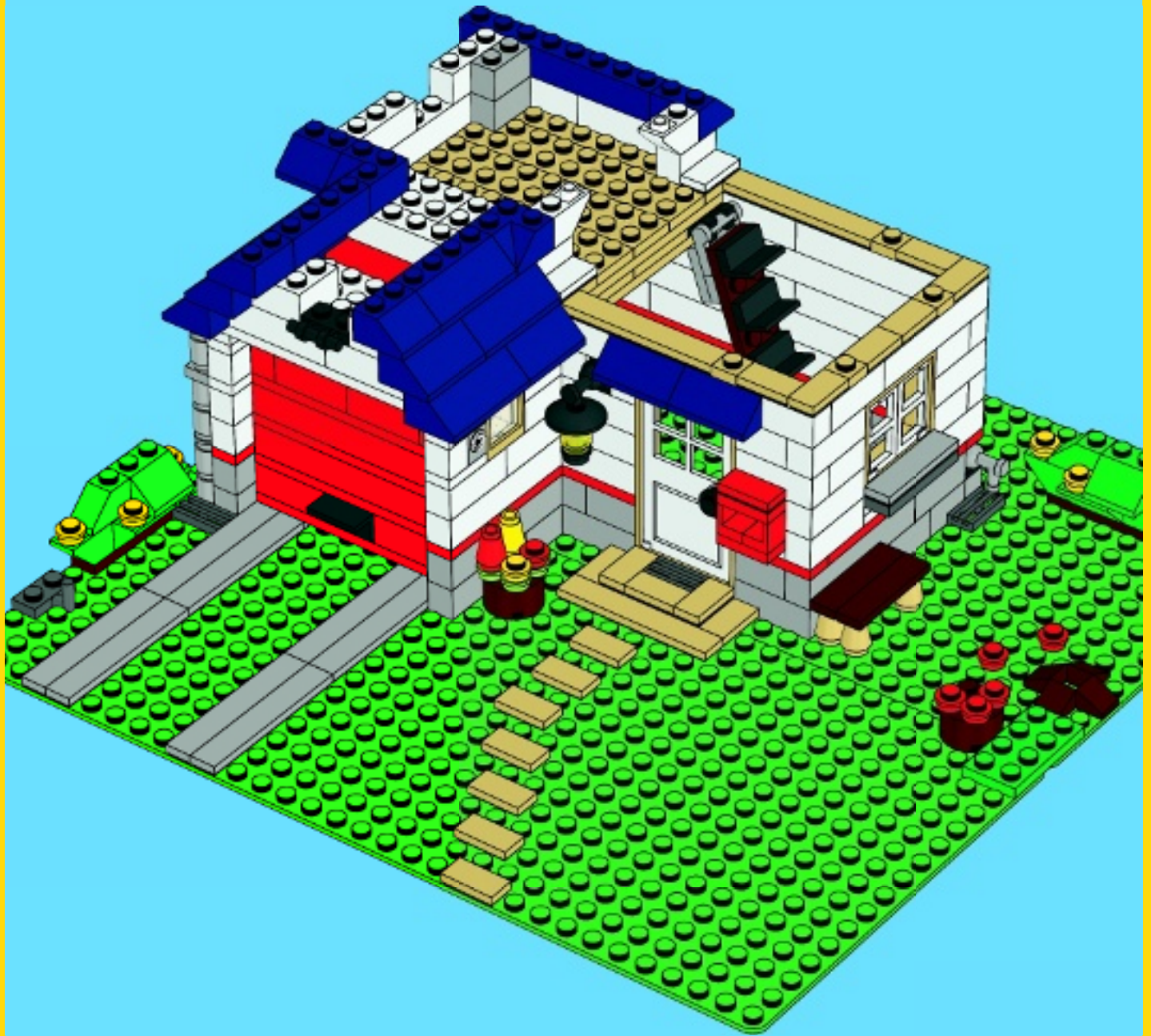



2x



2x



2x

38

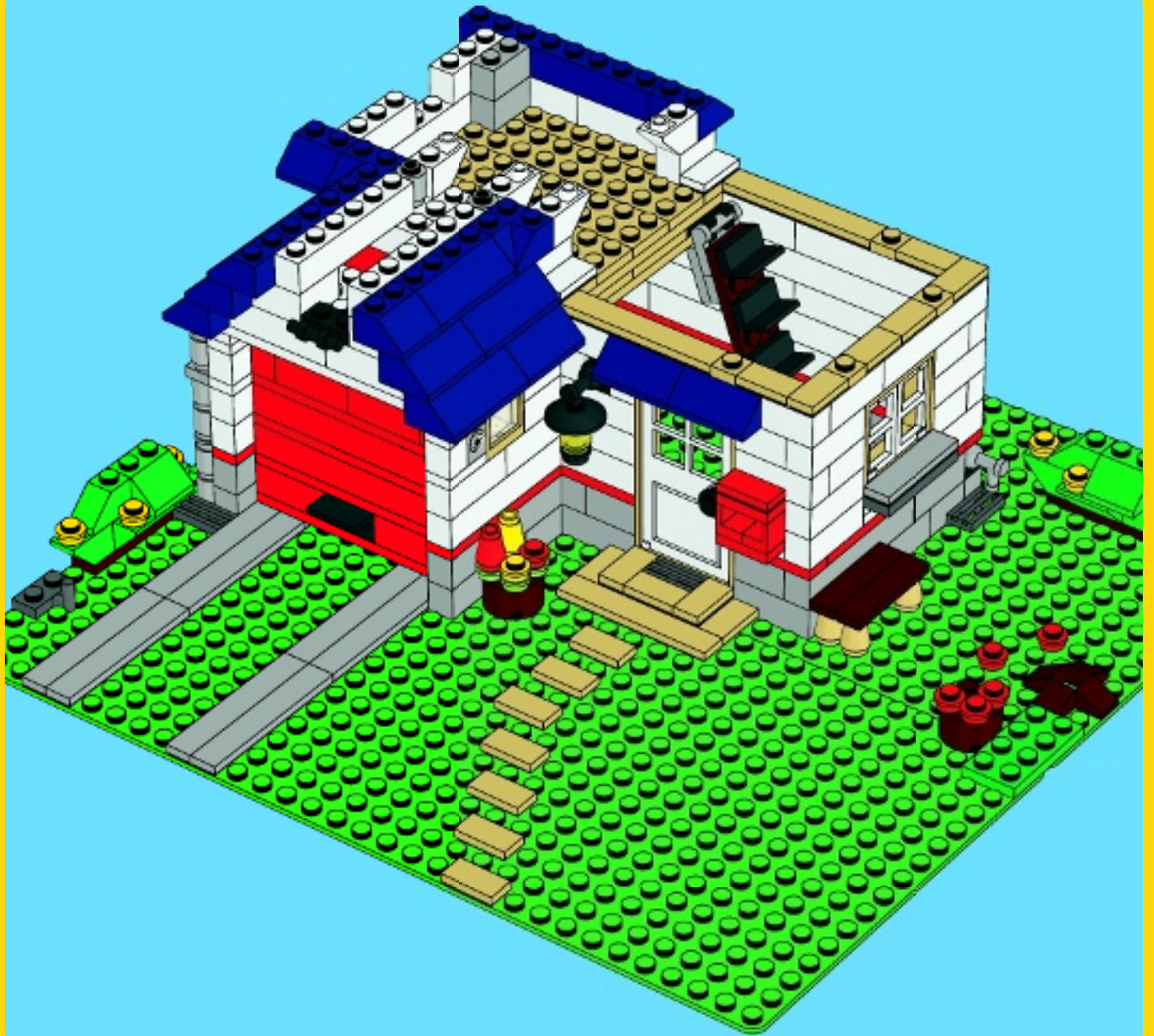

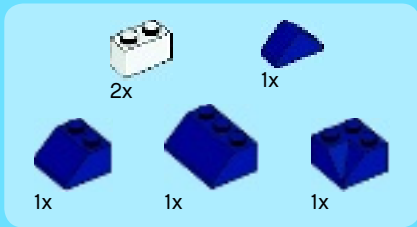

39



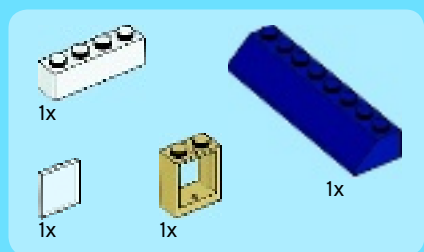

40

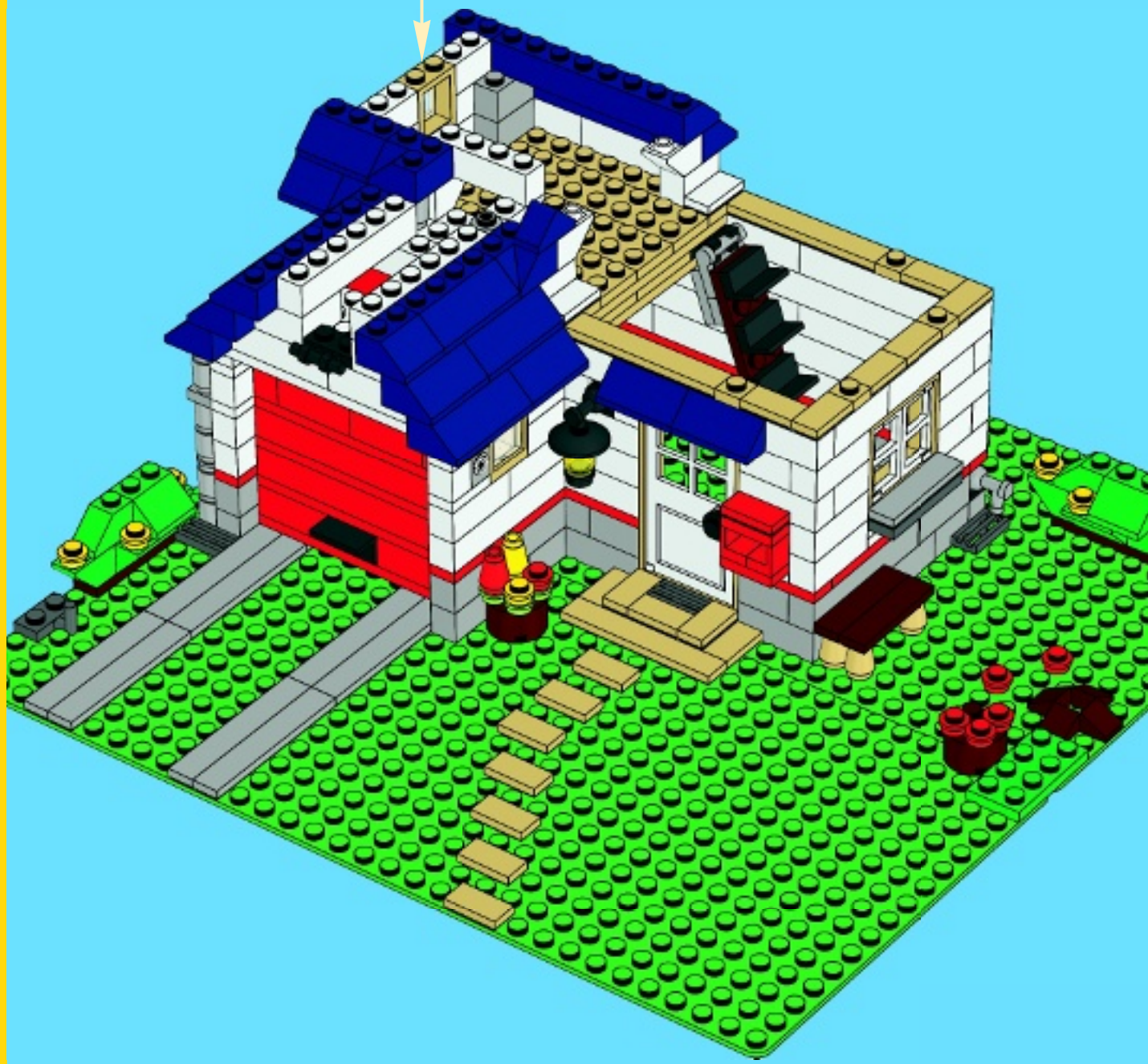
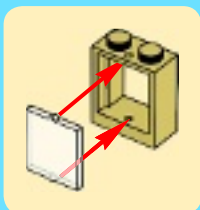



2x



1x



1x



2x



1x



1x

41

1

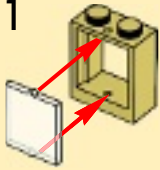

2

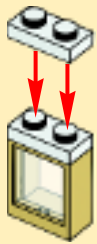

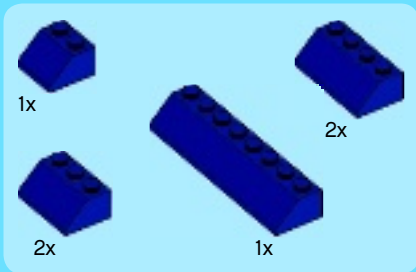

42



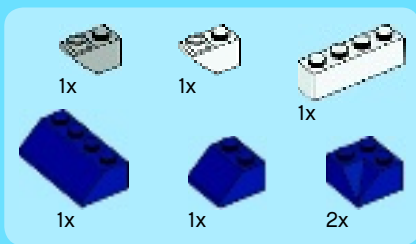

43



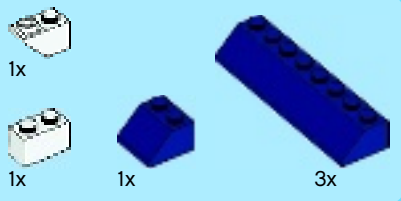

44



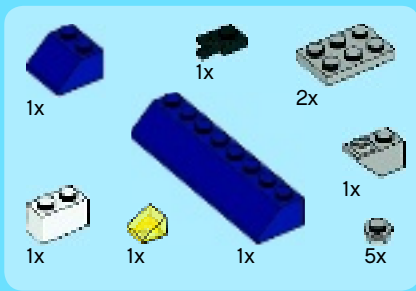

45



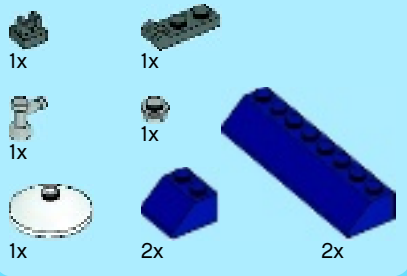

46



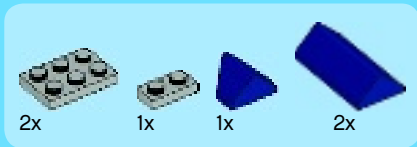

47



3x

1x

48



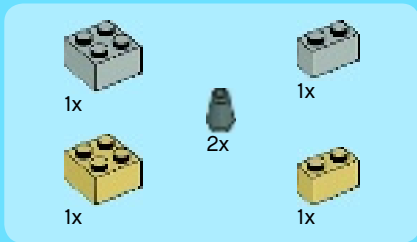

49

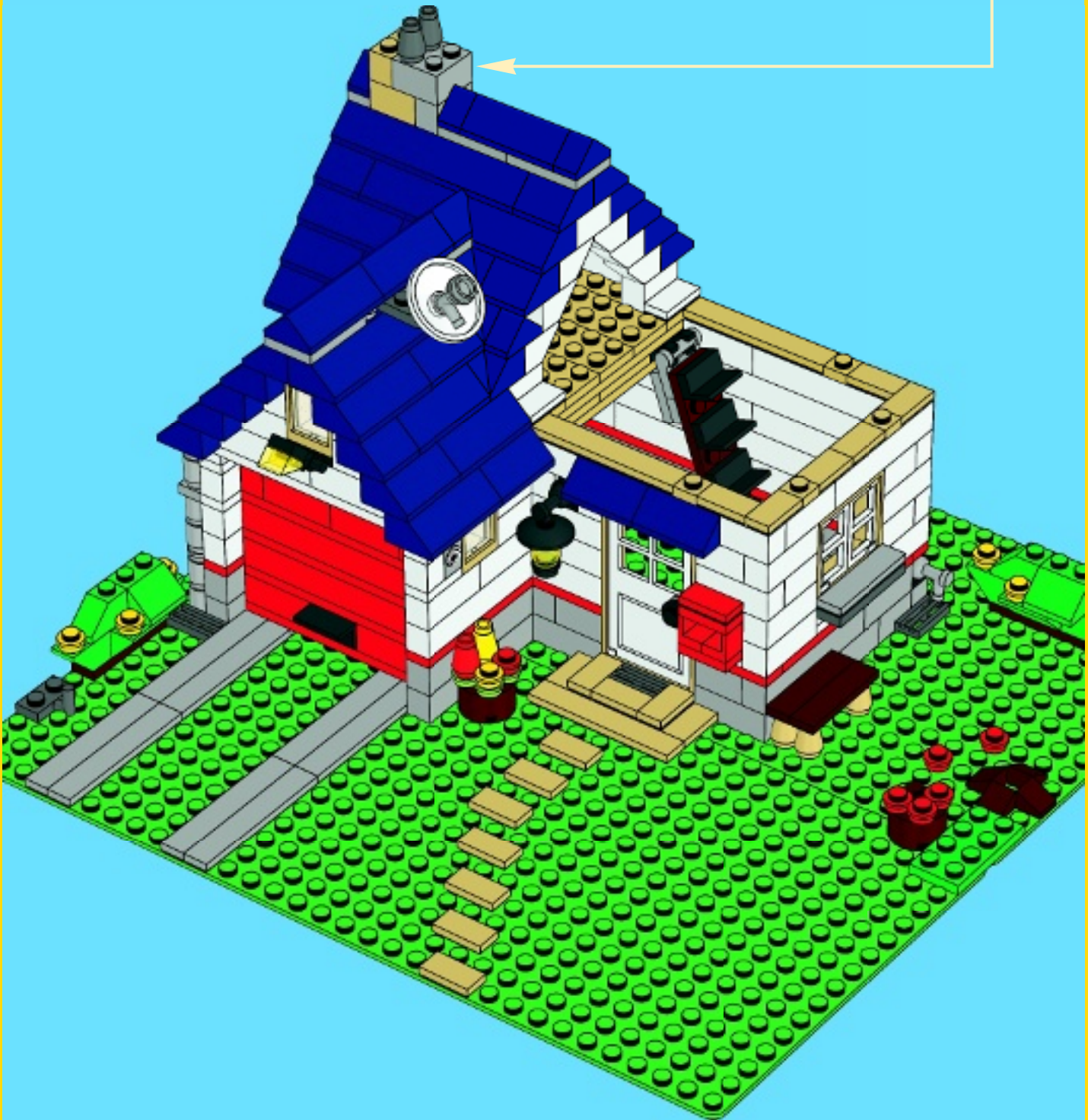
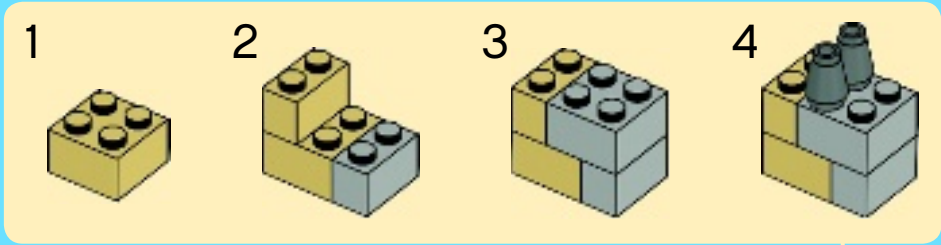

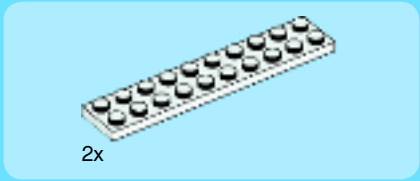
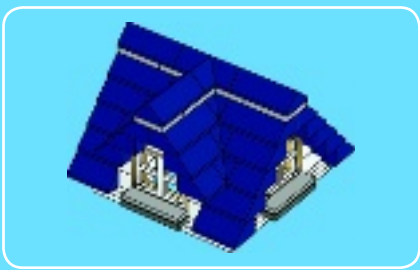

1

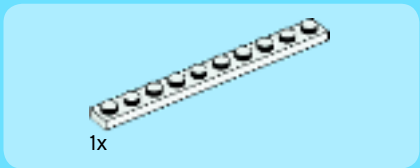
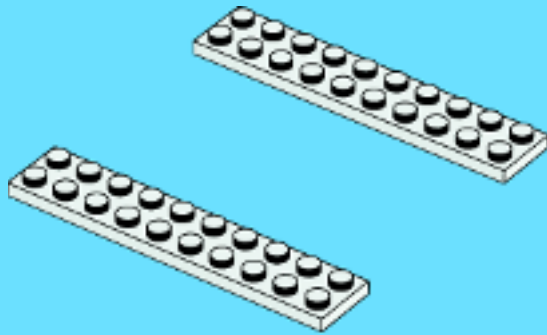

2

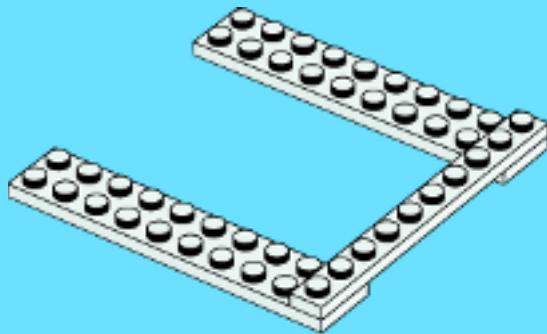



3

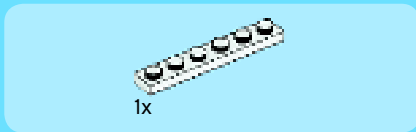
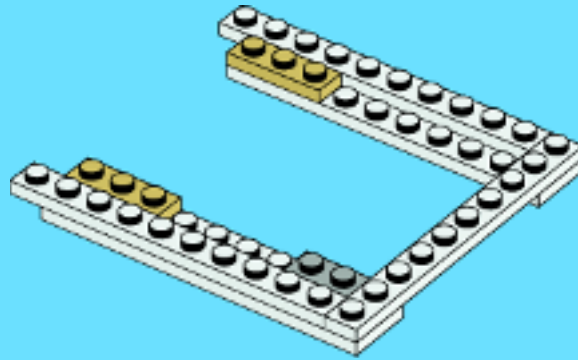

4

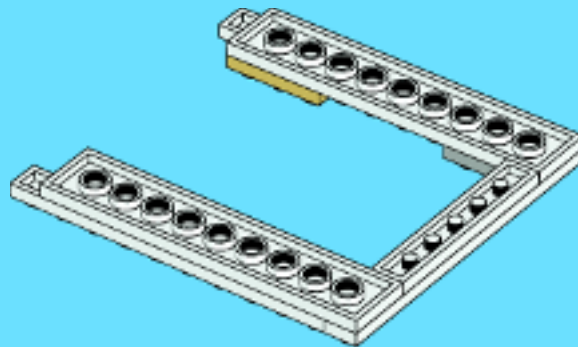

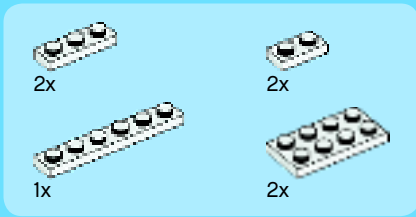

5

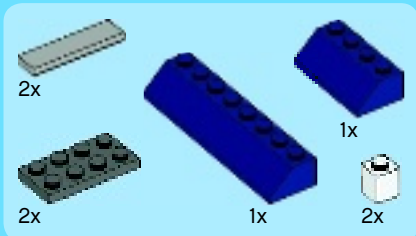
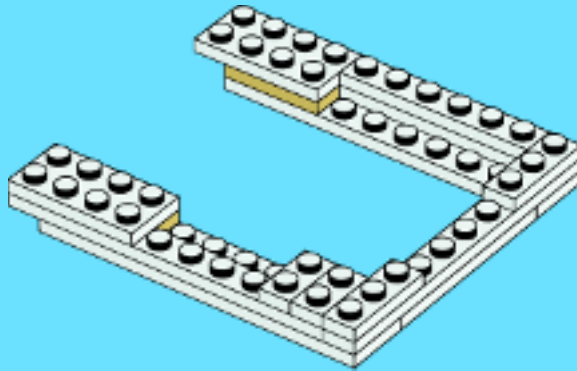

6

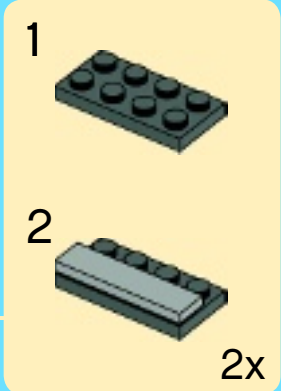
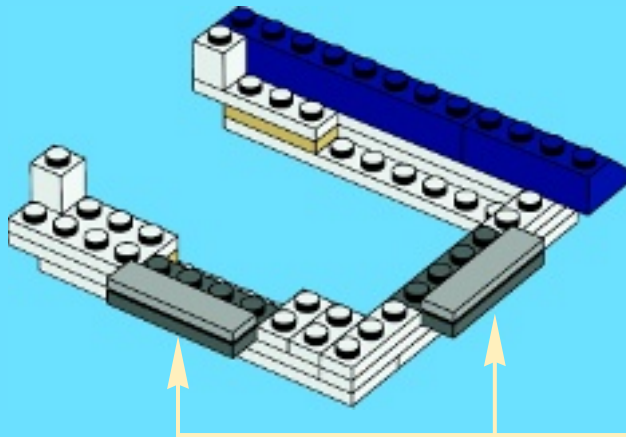

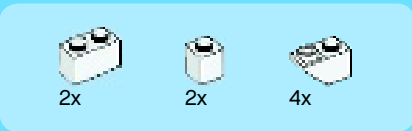

7

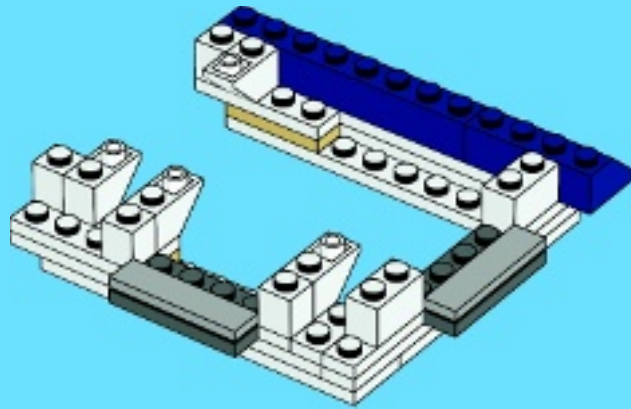

8

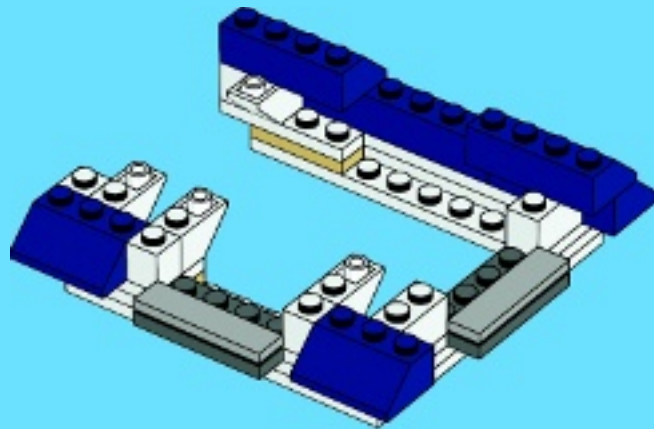

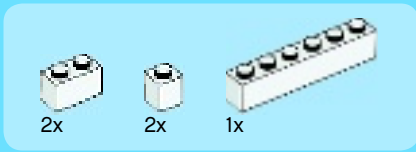

9

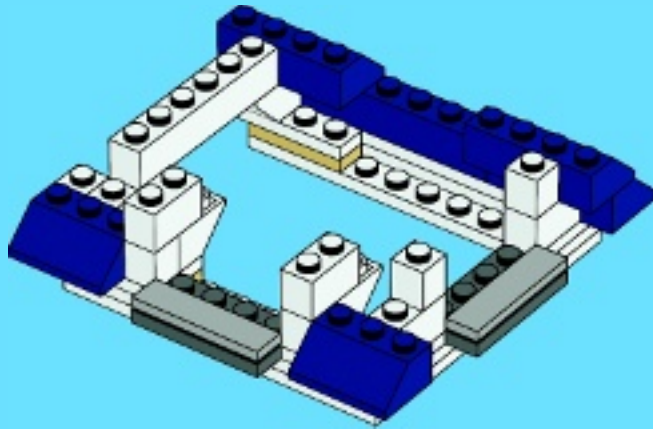

10

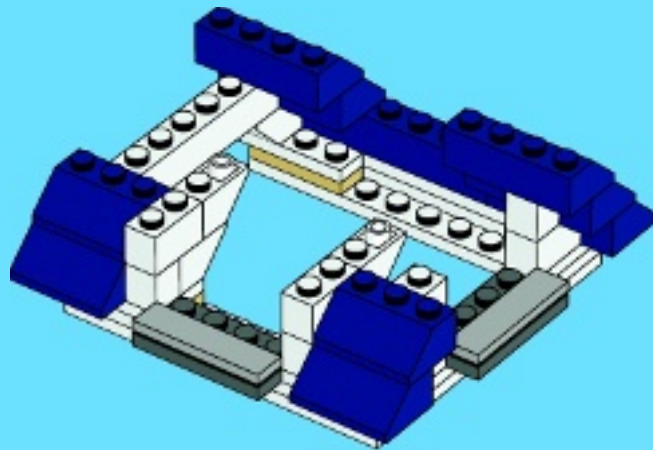



11

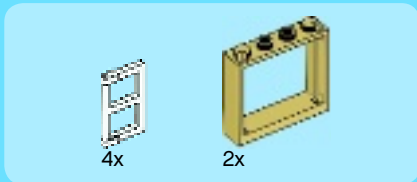
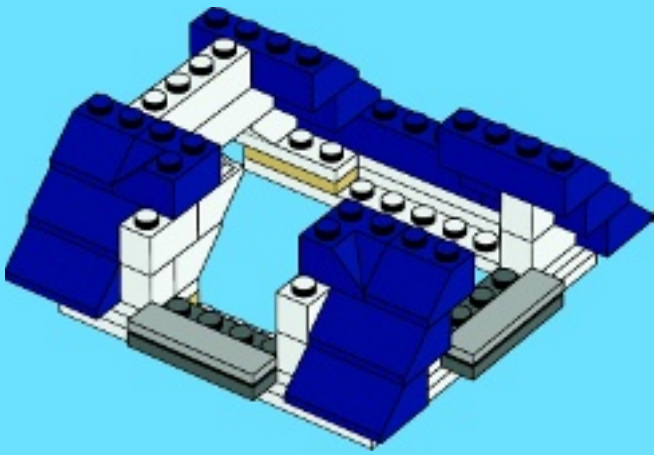

12

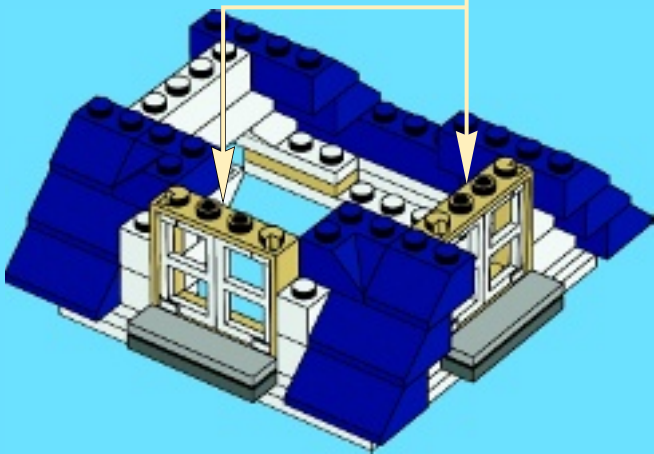
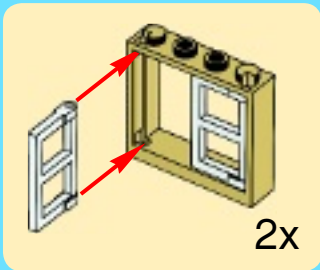

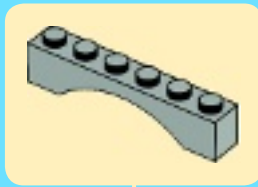
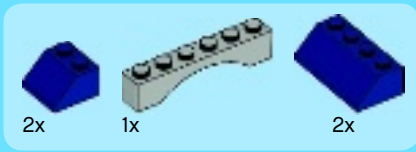

13

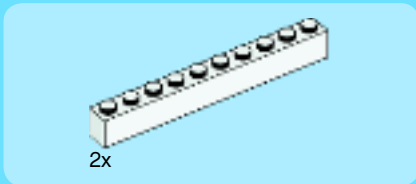
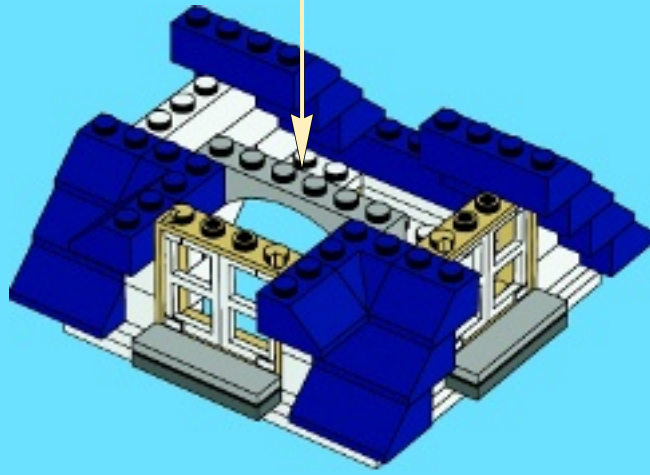

14

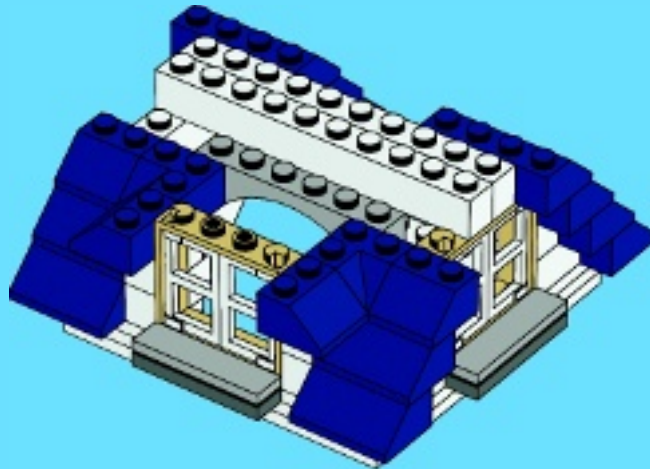



2x



2x

15

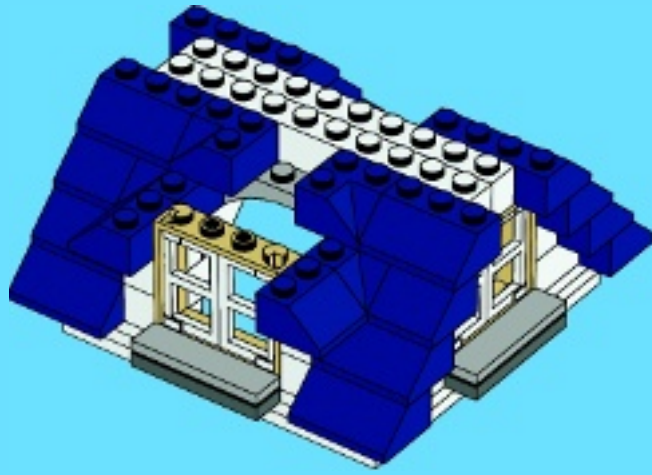

1x



2x

16

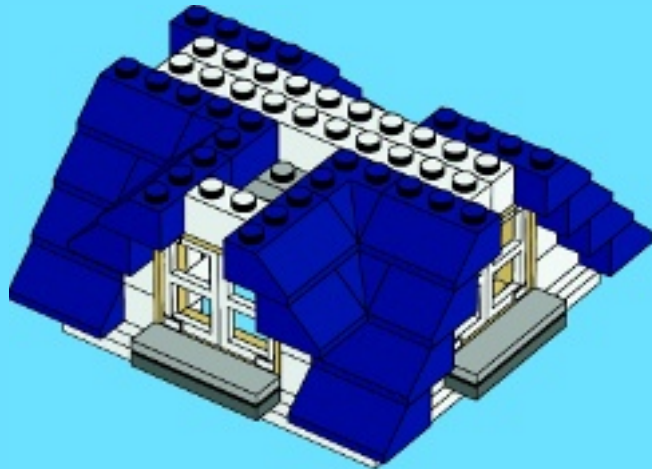

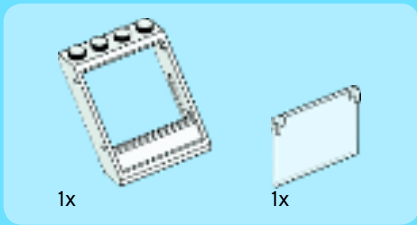

17

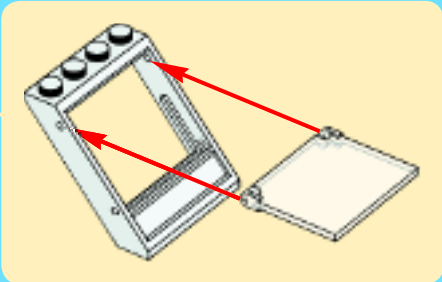
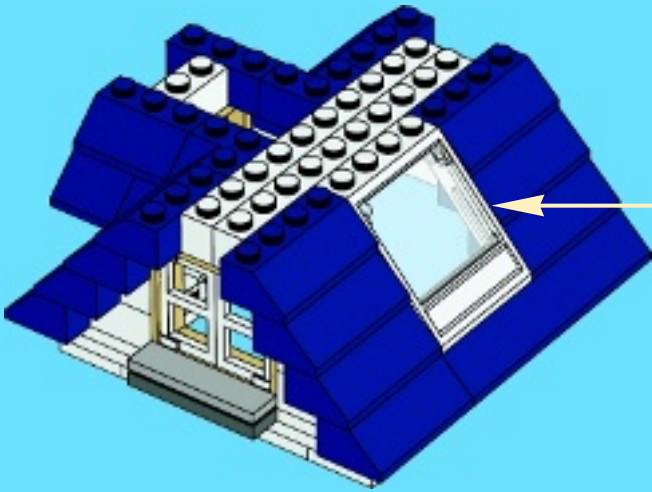

18

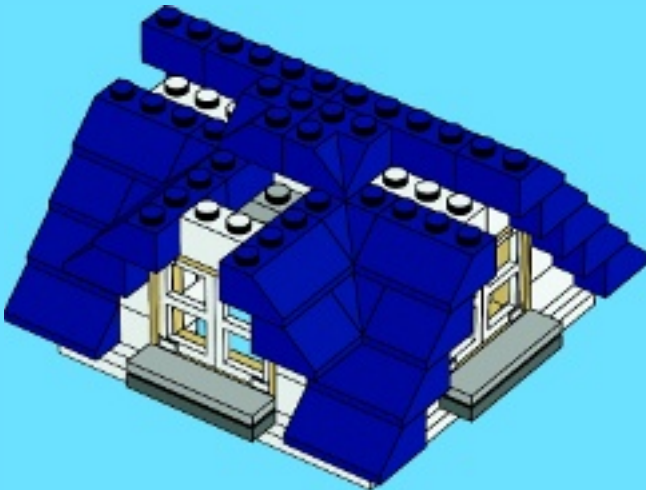



4x

19

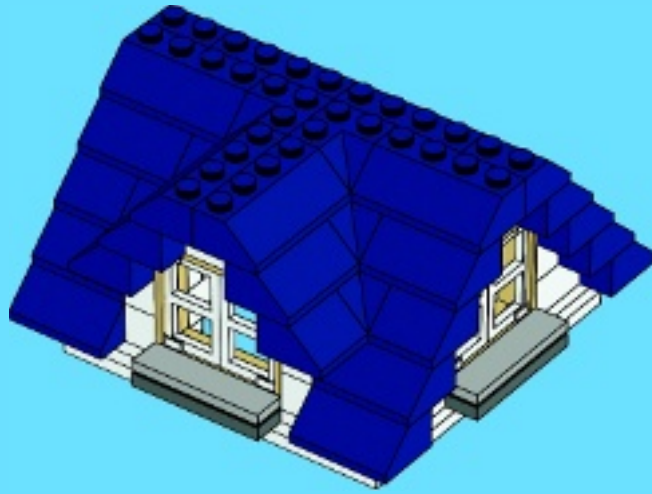

5x



1x

20

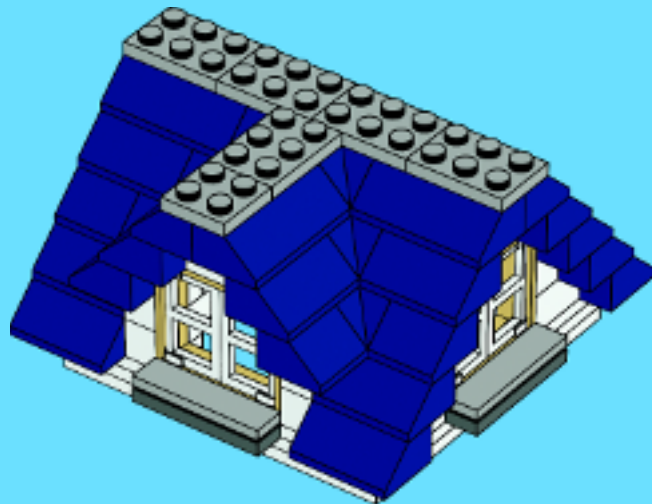



1x



4x

21

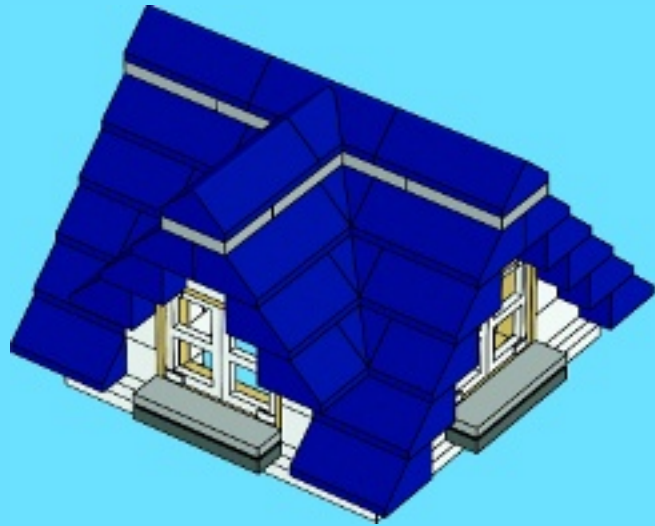

50



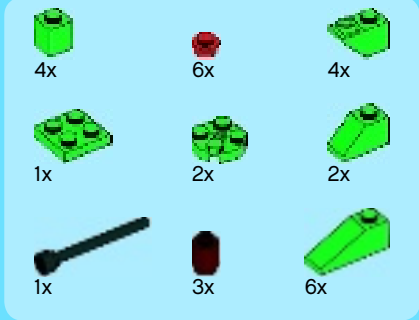

51

1



2



3

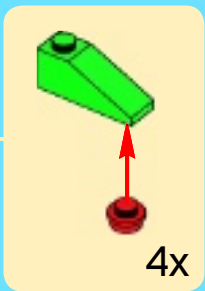

4

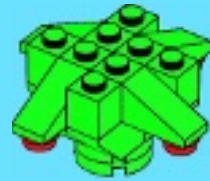

5

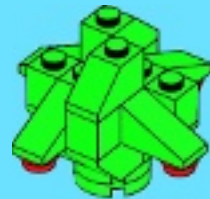

6

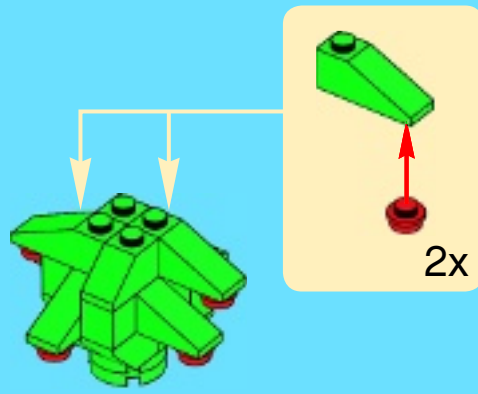

7



8

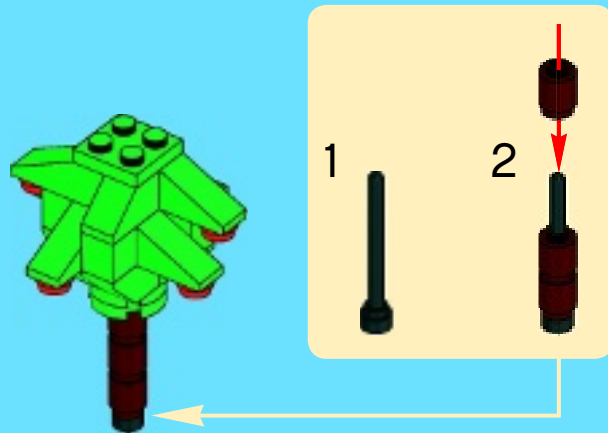





1x



1x



4x



1x



1x



4x



1x



1x



1x

52

1



2



3



4



5

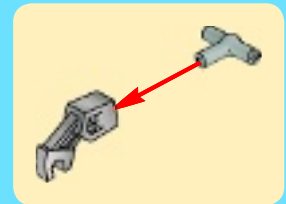

6



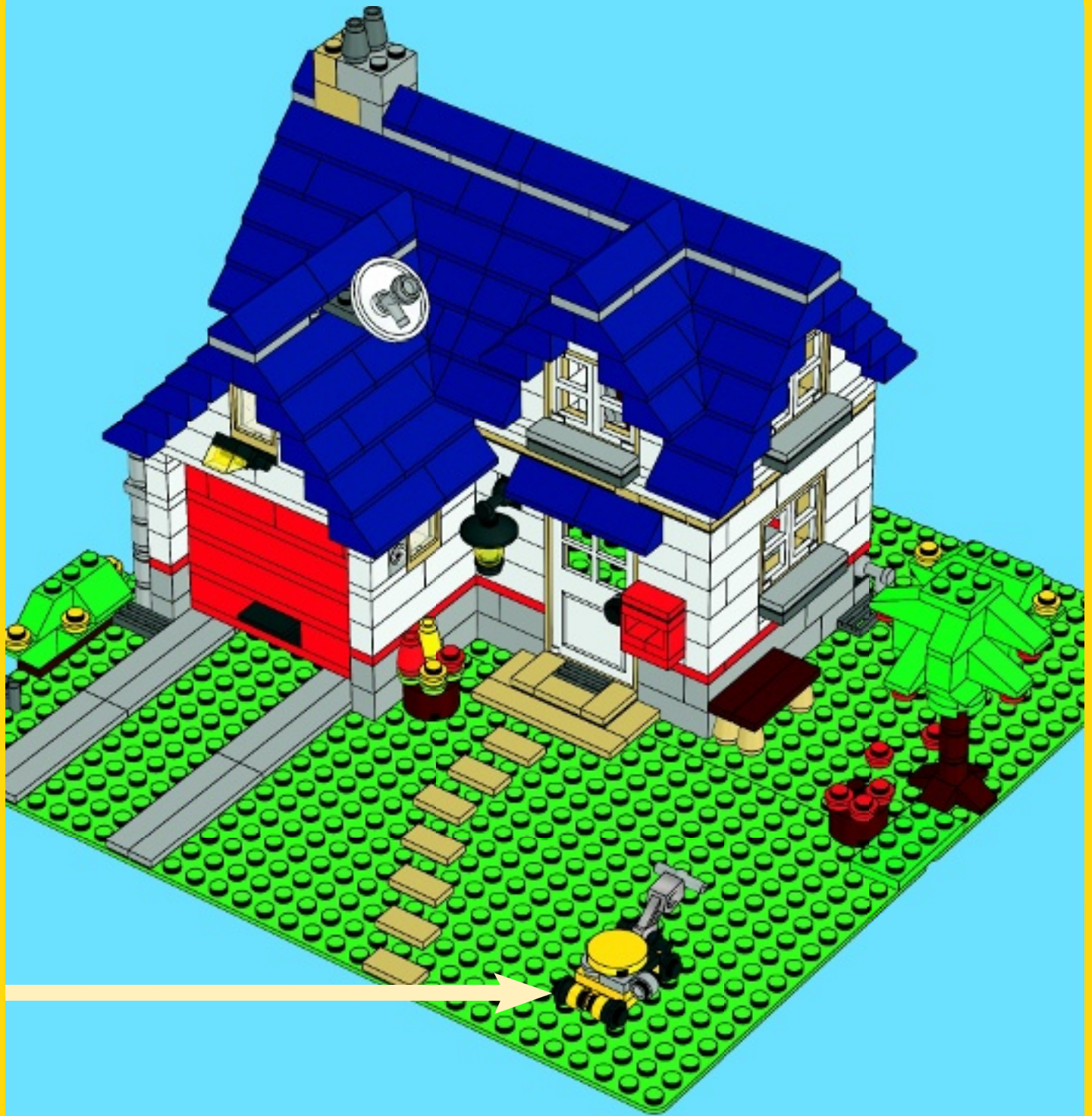

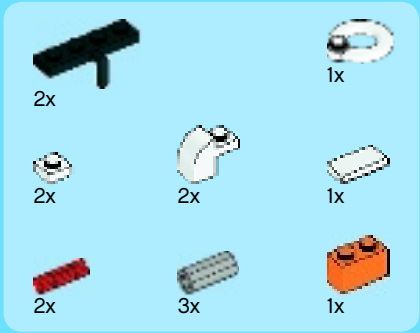

53



4

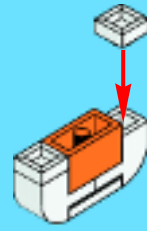

5



6

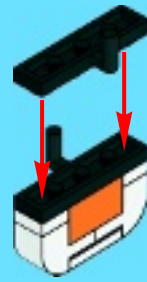

7





2x



3x

8

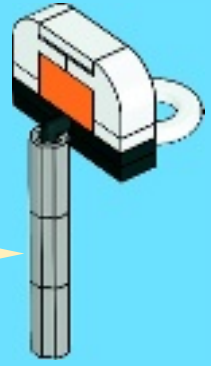
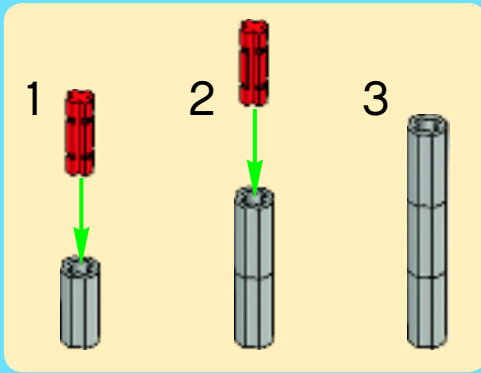



1x



2x

54





CREATOR



5866



5867



5891

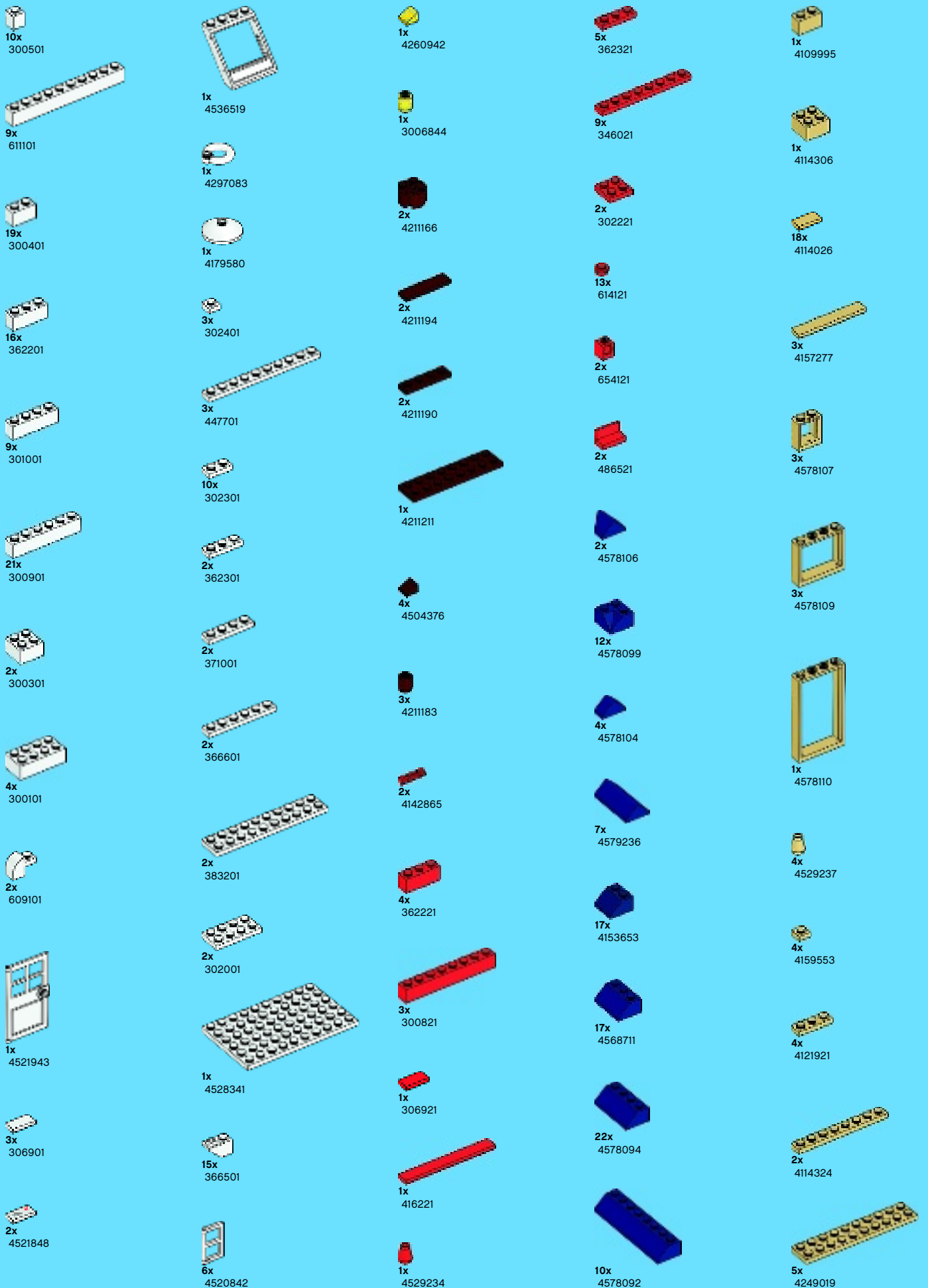

10x
300501

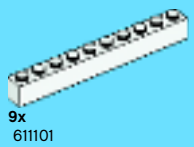

9x
611101



19x
300401

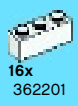

16x
362201



9x
301001



21x
300901

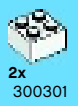

2x
300301



4x
300101



2x
609101



1x
4521943

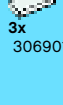

3x
306901

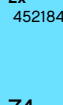

2x
4521848



1x
4536519



1x
4297083



1x
4179580



3x
302401



3x
447701



10x
302301



2x
362301



2x
371001



2x
366601

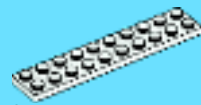

2x
383201



2x
302001



1x
4528341



15x
366501



6x
4520842



1x
4260942



1x
3006844



2x
4211166



2x
4211194



2x
4211190



1x
4211211



4x
4504376



3x
4211183



2x
4142865



4x
362221



3x
300821



1x
306921



1x
416221



1x
4529234



5x
362321



9x
346021



2x
302221



13x
614121



2x
654121



2x
486521



2x
4578106

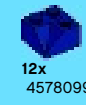

12x
4578099



4x
4578104



7x
4579236



17x
4153653



17x
4568711



22x
4578094



10x
4578092



1x
4109995



1x
4114306



18x
4114026



3x
4157277



3x
4578107



3x
4578109

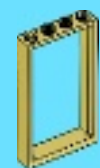

1x
4578110



4x
4529237



4x
4159553



4x
4121921



2x
4114324



5x
4249019

1x
415024

2x
4121715

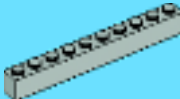
2x
4211521

8x
4211549

2x
4211503

4x
408124

4x
300528

10x
4211388

1x
4211477

2x
4211535

1x
4525464

1x
302328

6x
4211428

3x
4211398

2x
4529240

1x
302224

2x
302228

9x
4211393

1x
4244627

1x
4211069

7x
614124

2x
403228

1x
4211387

2x
4211397

1x
4521187

1x
4121739

2x
302028

1x
4211387

11x
4211396

3x
4211065

1x
4157103

8x
4142989

1x
4211424



3x
4211437

1x
4260885

4x
407026

4x
4121969

1x
4211353

1x
4211410

3x
4210631

1x
474026

6x
4107637

3x
4512360

8x
4211412

3x
4552035

3x
4517925

2x
303928

2x
4211414

8x
4211525

1x
4552033

2x
4140588

2x
4142717

3x
4211356

1x
4211508

1x
4494600

2x
3004326



7x
614126

1x
459926

5x
486526

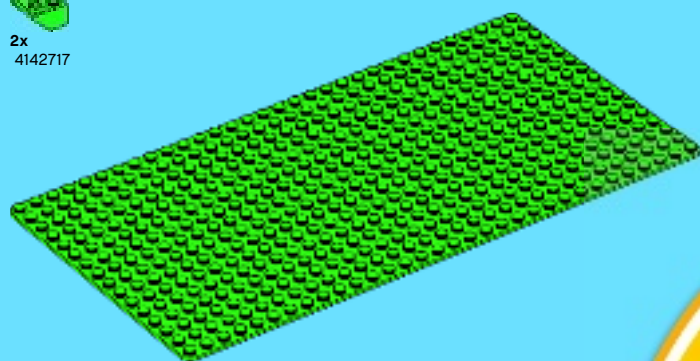

1x
395726

2x
4219648



Customer Service
Kundenservice
Service Consommateurs
Servicio Al Consumidor

www.lego.com/service or dial

: 00800 5346 5555
: 1-800-422-5346



WIN!

Go to www.nielsen.com/LEGO to fill out a survey for a chance to win a cool LEGO® Product. No purchase necessary. Open to all residents where not prohibited.

 www.LEGO.com



www.nielsen.com/LEGO

GEWINNE!

Nimm an der Umfrage auf www.nielsen.com/LEGO teil und hab die Chance ein cooles LEGO® Produkt zu gewinnen!
Die Teilnahme am Gewinnspiel führt zu keinerlei Kaufverpflichtungen. Teilnahme in allen nicht ausgeschlossenen Ländern möglich.

4584851

WIN!

Ga naar www.nielsen.com/LEGO, vul een enquêteformulier in en maak kans op een cool LEGO® product.
Geen aankoopverplichting.
Iedereen mag deelnemen, uitgezonderd ingezetenden van landen waar een enquêteverbod geldt.

GAGNE !

Visite www.nielsen.com/LEGO pour répondre à un questionnaire et avoir une chance de gagner un produit LEGO® très cool !
Aucune obligation d'achat.
Ouvert à tous les résidents des pays autorisés.

当てよう!

www.nielsen.com/LEGOにアクセスして、アンケートにご記入ください。当選者にはレゴ®製品を差し上げます。
お買い上げの必要はありません。
禁止されていない限り、すべての皆様にご利用いただけます。